

StarFood

UK English



DOC. NO. **H 171U 02**
EDITION 3 2004-01

NECTA
VENDING SOLUTIONS SpA
A company of
N&W GLOBAL VENDING GROUP

Sede legale: Via Roma 24
24030 Valbrembo (BG) Italia
Web: www.nwglobalvending.com

Telefono +39 035 606111
Fax +39 035 606460
Trib. Bergamo Reg. Imp. n. 2534
R.E.A. Bergamo n. 319295

DICHIARAZIONE DI CONFORMITA'
DECLARATION OF CONFORMITY
DÉCLARATION DE CONFORMITÉ
KONFORMITÄTSEKKLÄRUNG
DECLARACIÓN DE CONFORMIDAD
DECLARAÇÃO DE CONFORMIDADE
VERKLARING VAN OVEREENSTEMMING
INTYG OM ÖVERENSSTÄMMELSE
OVERENSSTEMMELSESERKLÆRING
YHDENMUKAISUUSTODISTUS

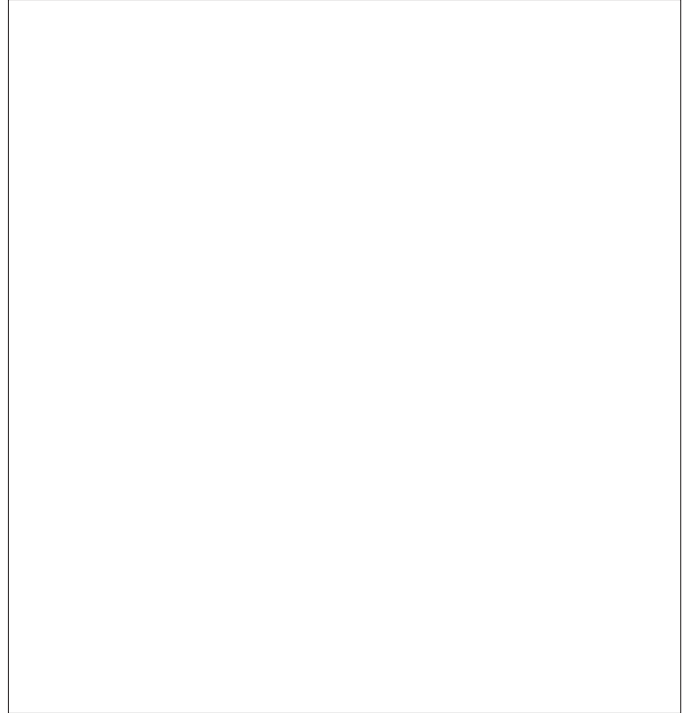

Valbrembo, 03/05/2001

Dichiara che la macchina descritta nella targhetta di identificazione, è conforme alle disposizioni legislative delle direttive: **89/392, 89/336, 73/23 CEE** e successive modifiche ed integrazioni.

Declares that the machine described in the identification plate conforms to the legislative directions of the directives: **89/392, 89/336, 73/23 EEC** and further amendments and integrations.

Déclare que l'appareil décrit dans la plaque signalétique satisfait aux prescriptions des directives: **89/392, 89/336, 73/23 CEE** et modifications/intégrations suivantes.

Erklärt, daß das im Typenschild beschriebene Gerät den **EWG** Richtlinien **89/392, 89/336, 73/23** sowie den folgenden Änderungen/Ergänzungen entspricht.

Declara que la máquina descrita en la placa de identificación, resulta conforme a las disposiciones legislativas de las directivas: **89/392, 89/336, 73/23 CEE** y modificaciones y integraciones sucesivas.

Declara que o distribuidor descrita na chapa de identificação é conforme às disposições legislativas das directivas **CEE 89/392, 89/336 e 73/23** e sucessivas modificações e integrações.

Verklaart dat de op de identificatieplaat beschreven machine overeenstemt met de bepalingen van de **EEG** richtlijnen **89/392, 89/336** en **73/23** en de daaropvolgende wijzigingen en aanvullingen.

Intygat att maskinen som beskrivs på identifieringsskylten överensstämmer med lagstiftningsföreskrifterna i direktiven: **89/392, 89/336, 73/23 CEE** och påföljande och kompletteringar.

Det erklæres herved, at automaten angivet på typeskiltet er i overensstemmelse med direktiverne **89/392, 89/336** og **73/23 EU** og de senere ændringer og tillæg.

Forsikrer under eget ansvar at apparatet som beskrives i identifikasjonsplaten, er i overensstemmelse med vilkårene i EU-direktivene **89/392, 89/336, 73/23** med endringer.

Vahvistaa, että arvokyltissä kuvattu laite vastaa **EU**-direktiivien **89/392, 89/336, 73/23** sekä niihin myöhemmin tehtyjen muutosten määräyksiä.

ANTONIO CAVO

C.E.O



THE INTERNATIONAL CERTIFICATION NETWORK

CERTIFICATE

**IQNet and its partner
CISQ/IMQ-CSQ**

hereby certify that the organization

NECTA VENDING SOLUTIONS SPA

VIA ROMA 24 - 24030 VALBREMBO (BG) Italy

VIA DEL CHIOSO ANG. CAPITANI DI MOZZO - 24030 MOZZO (BG) Italy

for the following field of activities

Design, manufacturing and sale of electronic/electromechanical vending machines

*Refer to quality manual for details of applications to ISO 9001:2000 requirements
has implemented and maintains a*

Quality Management System

which fulfills the requirements of the following standard

ISO 9001:2000

Issued on: 2002 - 09 - 04

Registration Number: IT - 12979

Fabio Roversi
President of IQNet



Gianrenzo Prati
President of CISQ

IQNet partners*:

AENOR, Spain AFAQ, France AIB-Vinotte International Belgium APCER, Portugal CISQ, Italy CQC, China CQM, China
CQS, Czech Republic DQS, Germany DS, Denmark ELOT, Greece FCAV, Brazil FONDONORMA, Venezuela HKQAA, Hong Kong
ICONTEC, Colombia IRAM, Argentina JOA, Japan KEMA, Netherlands KFQ, Korea MSZT, Hungary NCS, Norway
NSAI, Ireland OQS, Austria PCBC, Poland PSB, Singapore QMI, Canada SFS, Finland SII, Israel SIO, Slovenia SQS, Switzerland
IQNet is represented in the USA by the following partners: AFAQ, AIB-Vinotte International, CISQ, DQS, KEMA and NSAI

*The list of IQNet partners is valid at the time of issue of this certificate. Updated information is available under www.iqnet-certification.com

Federazione - Federation



a member of IQNet

CISQ è una Federazione
consorziale ed indipendente
di enti di certificazione dei Sistemi di
Gestione aziendali, operanti ciascuno
nel settore di propria competenza.

CISQ is a multi-sector, independent,
non-profit Federation of Italian
organizations for the certification
of company Management Systems,
each operating in its own sector
of responsibility.

CERTIFICAZIONE DEI SISTEMI DI GESTIONE AMBIENTALE DELLE AZIENDE
CERTIFICATION OF COMPANIES ENVIRONMENTAL MANAGEMENT SYSTEMS



CERTIFICATO n. **9191.ZAV2**
CERTIFICATE n.

SI CERTIFICA CHE IL SISTEMA DI GESTIONE AMBIENTALE DI
WE HEREBY CERTIFY THAT THE ENVIRONMENTAL MANAGEMENT SYSTEM OPERATED BY

NECTA VENDING SOLUTIONS S.p.A.

SITO
SITE

Via Roma, 24 - 24030 VALBREMBO (BG)

UNI EN ISO 14001

È CONFORME ALLA NORMA
IS IN COMPLIANCE WITH THE STANDARD

PER LE SEGUENTI ATTIVITÀ
CONCERNING THE FOLLOWING ACTIVITIES

Apparecchiature elettromeccaniche/elettroniche per la
distribuzione automatica e la ristorazione
Electronic/electromechanical vending-machines

IL PRESENTE CERTIFICATO È SOGGETTO AL RISPETTO DEL REGOLAMENTO
PER LA CERTIFICAZIONE DEI SISTEMI QUALITÀ ED I GESTIONE DELLE AZIENDE
THE USE AND THE VALIDITY OF THE CERTIFICATE SHALL SATISFY THE REQUIREMENTS
OF THE RULES FOR THE CERTIFICATION OF COMPANY QUALITY AND MANAGEMENT SYSTEMS

Prima emissione
First issue

19 Dicembre 1997

Emissione corrente
Current issue

31 Marzo 2000

La validità del presente certificato è subordinata a sorveglianza annuale e al riesame completo del Sistema di
Gestione Ambientale con periodicità triennale secondo le procedure dell'IMQ S.p.A.
The validity of the certificate is submitted to annual audit and a reassessment of the entire Environmental
Management System within three years according to IMQ S.p.A. rules

IMQ - VIA QUINTILIANO, 43 - 20139 MILANO



E.A. 19

TABLE OF CONTENTS

INTRODUCTION	PAGE 2	TECHNICIAN MENU	PAGE 14
IDENTIFICATION OF THE VENDING MACHINE	PAGE 2	PRESENT FAILURES	PAGE 14
IN THE EVENT OF FAILURES	PAGE 2	PROGRAMMING THE PARAMETERS	PAGE 15
TRANSPORT AND STORAGE	PAGE 2	CASH	PAGE 15
USING THE VENDING MACHINE	PAGE 2	COIN MECHANISMS	PAGE 15
POSITIONING THE VENDING MACHINE	PAGE 3	COMMON FUNCTIONS	PAGE 17
WARNING FOR INSTALLATION	PAGE 3	DRUMS / SLIDERS	PAGE 17
PRECAUTIONS IN USING THE MACHINE	PAGE 3	COLD PARAMETERS	PAGE 18
WARNING FOR SCRAPPING	PAGE 3	DISPLAY	PAGE 18
TECHNICAL SPECIFICATIONS	PAGE 4	MISCELLANEOUS	PAGE 19
POWER CONSUMPTION	PAGE 4	PASSWORD	PAGE 19
MAIN FEATURES	PAGE 4	ENERGY SAVING	PAGE 19
		DISPLAYING THE FILLER MENU	PAGE 19
		STATISTICS	PAGE 19
		TEST	PAGE 21
		SLIDER TEST	PAGE 21
		COMPLETE SELECTIONS	PAGE 21
		MISCELLANEOUS	PAGE 21
		MACHINE INFORMATION	PAGE 21
		INITIALISING	PAGE 21
		GSM	PAGE 22
		EVADTS CODES	PAGE 22
LOADING AND CLEANING	PAGE 5		
VENDING SYSTEMS	PAGE 5		
DISPENSING CYCLE	PAGE 5		
WARNING FOR LOADING	PAGE 5		
CONTROLS AND INFORMATION	PAGE 5		
INTERNAL COMPONENTS	PAGE 6		
LOADING SWITCH	PAGE 6		
PROGRAMMING SWITCH	PAGE 6		
HYGIENE AND CLEANING	PAGE 7		
LOADING PRODUCTS	PAGE 7		
ROUTINE MAINTENANCE	PAGE 8		
PERIODICAL CLEANING	PAGE 8		
SUSPENDING FROM USE	PAGE 8		
		MAINTENANCE	PAGE 23
		PRINTED BOARD FUNCTIONS AND INDICATOR LAMPS	PAGE 23
		CPU BOARD	PAGE 23
		ACTUATION BOARD	PAGE 24
		CONFIGURING THE C.P.U. BOARD	PAGE 24
		SOFTWARE UPDATE	PAGE 24
		SELF-DIAGNOSIS FUNCTION	PAGE 25
		DRUM MAINTENANCE	PAGE 26
		ASSEMBLY OF THE PRODUCT DRUMS	PAGE 26
		CHANGING THE COMPARTMENTS OF A DRUM	PAGE 26
		DISASSEMBLING THE DRUM STACK	PAGE 27
		COOLING SYSTEM	PAGE 28
		AUTOMATIC DEFROSTING DEVICE	PAGE 28
		MAINTENANCE AND CLEANING	PAGE 28
		POWER SUPPLY UNIT	PAGE 28
		PROGRAMMING MENU - SUMMARY	PAGE 29
		WIRING DIAGRAM	PAGE 54
INSTALLATION	PAGE 9		
UNPACKING THE VENDING MACHINE	PAGE 9		
CONNECTION TO THE POWER SUPPLY	PAGE 9		
INSTALLING THE PAYMENT SYSTEM	PAGE 9		
OPERATING MODES	PAGE 10		
USER INTERFACE	PAGE 10		
NORMAL OPERATING MODE	PAGE 10		
LOADING	PAGE 11		
AUTO-CONFIGURATION	PAGE 11		
FILLER MENU	PAGE 12		
STATISTICS	PAGE 12		
SELECTION PRICES	PAGE 12		
CHANGE TUBES CONTROL	PAGE 12		
ADJUSTING THE AIRFLOW	PAGE 12		
ANTI-TAMPERING CHECK	PAGE 13		
TEST	PAGE 13		
EVADTS TRANSFER	PAGE 13		

INTRODUCTION

This technical documentation is part and parcel of the vending machine and must always follow the machine in case it is moved or transfer of ownership, so as to allow consultation by different operators.

Before starting installation and using the machine, it is first necessary to carefully read and understand the instructions contained in this manual, as they offer important information on installation safety, operating instructions and maintenance.

This manual is divided into three chapters.

The **first chapter** describes the loading and routine maintenance operations which are carried out in areas of the machine accessible with simple use of the door key, without using any other tools.

The **second chapter** contains the instructions for correct installation and all information necessary for optimum use of the machine.

The **third chapter** describes maintenance operations which involve the use of tools to access potentially dangerous areas.

The operations described in the second and third chapters must be carried out only by personnel who have the specific knowledge of the machine functioning from a point of view of electrical safety and health regulations.

IDENTIFICATION OF THE VENDING MACHINE AND ITS CHARACTERISTICS

Each machine is identified by its own serial number, indicated on the rating plate attached inside the cabinet on the right side.

This plate is the only one acknowledged by the manufacturer as identification of the machine, and carries all data which readily and safely gives technical information supplied by the manufacturer. It also assists in the spare parts management.

IN THE EVENT OF FAILURES

In most cases, any technical problems are corrected by small repair operations; however, before contacting the manufacturer we recommend that this manual be read carefully.

Should there be serious failures or malfunctions, then contact the following:

NECTA VENDING SOLUTIONS SpA
Via Roma 24
24030 Valbrembo
Italy - Tel. +39 035606111

TRANSPORT AND STORAGE

To prevent any damage, special care should be taken when loading or unloading the vending machine.

The machine can be lifted by a motor-driven or manual forklift truck, and the forks are to be placed underneath the machine from the side clearly indicated by the symbol on the cardboard package.

Do not:

- overturn the vending machine;
- drag the vending machine with ropes or similar;
- lift the vending machine by its sides;
- lift the vending machine with slings or ropes;
- shake or jolt the vending machine and its packing.

The machine should be stored in a dry room where the temperature remains between 0°C and 40°C.

Avoid stacking machines one on top of the other and always keep it upright as indicated by the arrows on the packing.

USING THE VENDING MACHINE FOR HERMETICALLY SEALED PRODUCTS

A different sale price can be set for each product selection by the machine electronic control. The various functions are programmed through the selection buttons without any need for additional equipment.

All models are fitted with variable configuration drums, permitting the number of partitions to be either increased or reduced to adapt the machine to the size of the products to be dispensed, thus optimising the machine capacity.

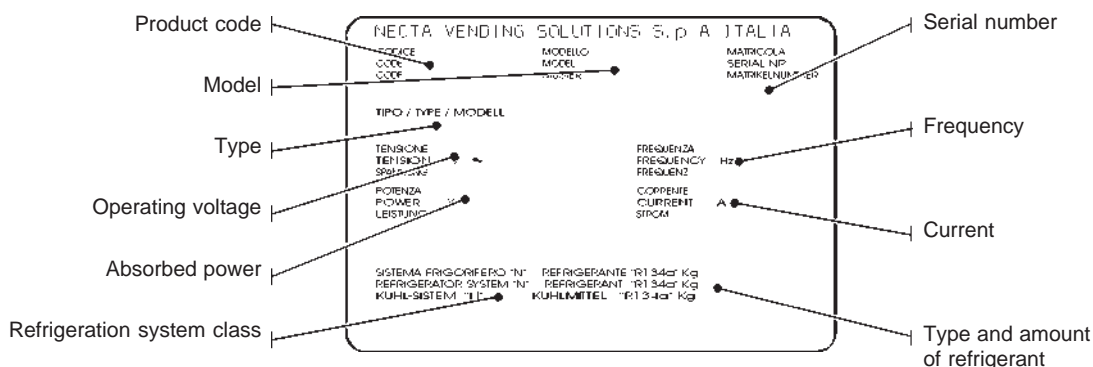

The vending machine is suitable for dispensing food that is hermetically sealed and kept refrigerated.

Strictly comply with the producer's specifications regarding storage temperature and expiry date for each product.

Any other use is unsuitable and thus potentially dangerous.

POSITIONING THE VENDING MACHINE

The vending machine is not suitable for outdoor installation. It must be positioned in a dry room where the temperature remains between 5°C and 32°C, and not where water jets are used for cleaning (e.g. in large kitchens, etc.). To ensure correct machine operation we recommend installing the air baffle plate / spacer to the back of the machine.

Screw the 2 quick-snap pins, supplied with the machine, to the rear feet and insert the clips into the holes provided on the spacer.

Insert the baffle plate's tangs into the special slots and click on the clips.

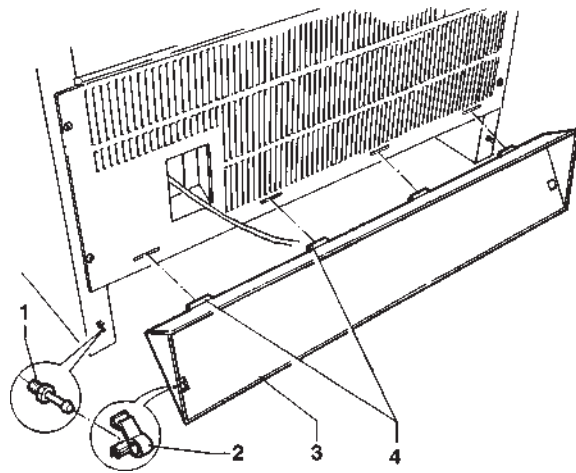

Fig. 1

- 1 - Quick-snap pins
- 2 - Clips
- 3 - Air baffle plate / spacer
- 4 - Tangs

The machine should be positioned with a maximum inclination of 2°.

If necessary provide proper levelling by way of the adjustable feet included.

A front foot panel is available as accessory.

WARNING FOR INSTALLATION

The machine installation and the following maintenance operations should be carried out by qualified personnel only, who are trained in the correct use of the machine according to the standards in force.

The machine is sold without payment system, therefore the installer of such a system is responsible for any damage to the machine or to things and persons caused by faulty installation.

The integrity of the machine and compliance with the standards of the relevant systems must be checked at least once a year by qualified personnel.

PRECAUTIONS IN USING THE MACHINE

The following precautions will assist in protecting the environment:

- use biodegradable products only to clean the machine;
- adequately dispose of all containers of the products used for loading and cleaning the machine;
- switch off the machine lighting during periods of inactivity, thus achieving considerable energy savings;
- keep the machine away from heat sources;
- regularly check the condition of the door seal to limit any heat dispersion;
- limit as much as possible door opening time during loading operations to avoid temperature increase inside the cabinet and subsequent power consumption.

WARNING FOR SCRAPPING

Whenever the machine is to be scrapped, the laws in force regarding environment protection should be strictly observed. More specifically:

- ferrous and plastic materials and the like are to be disposed of in authorized areas only;
- insulating materials and the gas inside the cooling unit (see the data plate), should be recovered by qualified companies by means of special equipment.

TECHNICAL SPECIFICATIONS

Power supply voltage	230	V~
Power supply frequency	50	Hz
Max absorbed power	1300	W
Lighting lamps 2x	36	W

DIMENSIONS

Height	(A)	1830	mm
Width	(B)	850	mm
Depth	(C)	895	mm
Overall depth	(D)	1650	mm
Weight (with packing)		359	Kg

Fig. 2

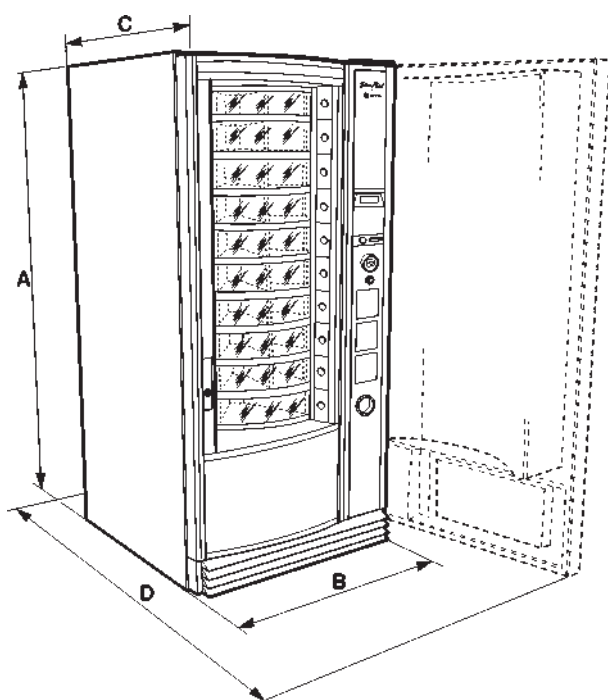

REFRIGERATING SYSTEM

Operating conditions:

Max temperature: 32° C, max relative humidity: 75%

Compressor: 18 cm³

0.3 Kg of R134a refrigerant

Fan-forced evaporator

Programmable defrosting cycle

PAYMENT SYSTEM

The machine is supplied with all electrical prearrangement for systems with Executive, BDV and MDB protocol, as well as for installation of 24 V DC validators.

Beside the coin mechanism housing, suitable space is provided for the installation (optional) of the most widely used payment systems.

SALES PRICES

For each single selection, a different price can be set in 4 time bands, programmable for each day of the week; the standard setting has the same price for all selections, without using time bands.

COIN BOX

Cover and lock are available as an optional feature.

POWER CONSUMPTION

The machine power consumption depends on many factors, such as temperature and ventilation of the room where it is installed, temperature of loaded products, internal temperature of the refrigerated box.

Under average conditions, and namely:

- Ambient temperature: 20° C
- Refrigerated box temperature: 3° C
- temperature of loaded products (machine completely empty) 5° C

the following power consumption levels resulted:

- to reach operating temperature 12,460 Wh
- Hourly stand-by power consumption 505 Wh

The above power consumption calculated from average data should only be taken as an indication.

PERFORMANCE

The machine has been designed to dispense products which are very different from each other; therefore all drums are modular and can be configured with various combinations to satisfy many different needs.

- Each drum can be subdivided into 6, 12, 18, 24 or 36 sectors.
- Microprocessor control.
- Coin mechanisms or electronic payment systems with interface for the most widely used communication protocols can be installed (Executive, BDV, MDB), alternatively, parallel-type validators can be used.
- Liquid Crystal Display, for messages to the user and for programming functions.
- Liquid Crystal Display for each drum to indicate the sales price.
- Cooling unit with electronic temperature control.

Chapter 1 LOADING AND CLEANING

VENDING SYSTEMS



- **Shopper:** by pressing the rotation button , the desired product can be brought to dispensing position (on the right hand side of the slider window).
- **First in/First out:** The product is brought to dispensing position (First out) with the same sequence of loading (First in).
The product availability is checked by counting the number of selections made in relation to the number of sectors.

It is however possible to have a combination of the two systems in any desired sequence.

The following options are also possible with a suitable type of coin mechanism:

- **Single vend:** The change is returned automatically at the end of the selection procedure.
- **Multivend:** After the selection procedure, the credit is available for other selections until it is claimed through the coin return button.
- **With purchase obligation:** At least one selection must be made to be able to claim the money inserted.
- **Without purchase obligation:** The money inserted can be claimed at any time through the coin return button.

DISPENSING CYCLE

When keeping the rotation button  pressed the drums programmed for “shopper” mode start rotating. When releasing button  the drum rotation is stopped and the desired product is brought to dispensing position (on the right hand side of the slider window).

The drums which are programmed for First in/First out mode, or that are empty, do not rotate.

Each single disk has its own selection button; if there is sufficient credit, when pressing the button corresponding to the desired disk, the slider opens automatically to allow the product to be picked up.

After a programmable time (10 seconds by default) the slider closes and the empty sector moves to the right.

During the closing phase the slider can be reopened, within 10 seconds, by pressing any button

N.B.

Should the slider be obstructed during the closing phase, four consecutive closing attempts will be made before disabling the machine.

For the following 10 minutes the closing attempts will be repeated every minute, then the machine will lock.

The closing attempts are indicated by a sound and on the display.

The vending machine is suitable for dispensing food that is hermetically sealed and kept refrigerated.

WARNING FOR LOADING

Before reloading the machine **check** that the **expiry date** of any unsold products has not been exceeded.

Loading operations should be carried only when the room temperature is between 2°C and 32°C.

CONTROLS AND INFORMATION

The user controls and information are on the outside of the door.

The credit and all function messages are indicated on the display.

Button  is used to rotate the drums which are programmed for “shopper” dispensing.

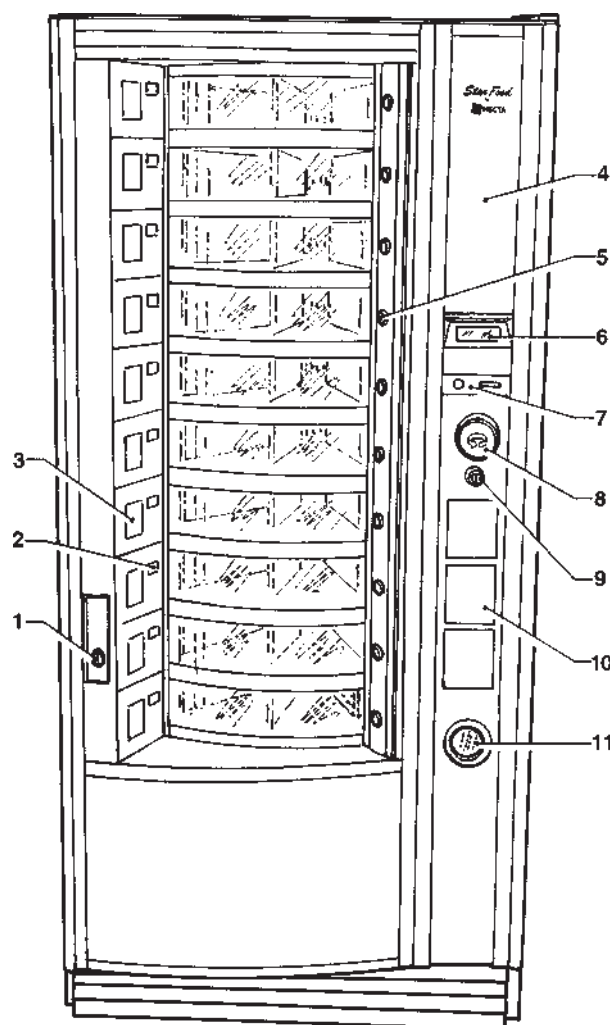

Fig. 3

- | | |
|----|---------------------------------------|
| 1 | Lock for refrigerated box |
| 2 | Price indicator display |
| 3 | Product labels |
| 4 | Space for payment system installation |
| 5 | Selection buttons |
| 6 | Liquid crystal display |
| 7 | Coin slot / return button |
| 8 | Drum rotation button |
| 9 | Lock for payment system door |
| 10 | Space for user information |
| 11 | Coin return flap |

INTERNAL COMPONENTS

The cooling unit positioned in the lower section of the cabinet ensures correct product temperature.

The evaporator is defrosted automatically every 6 hours by reversing the gas flow. The timing can however be programmed between 1 and 99 hours.

The C.P.U. (central processing unit) board, accessed from the payment system compartment, and the power board, located on the door, control the different functions of the vending machine.

The power supply unit, located in the lower section of the cabinet, contains the protection fuses and the main switch.

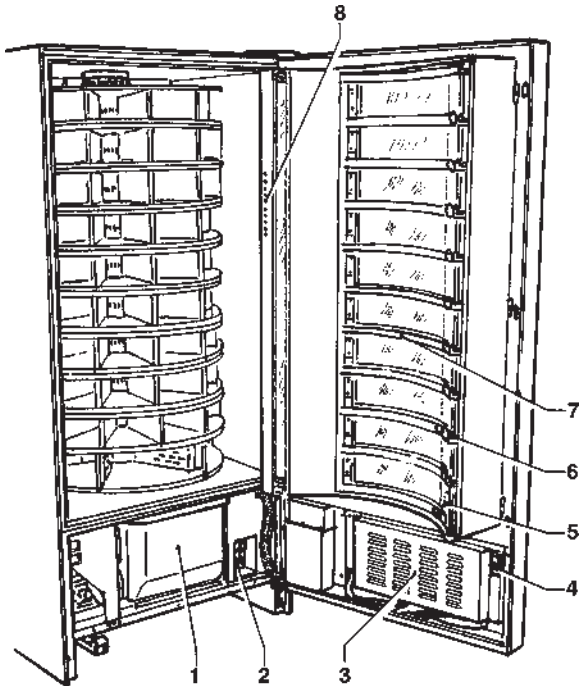

Fig. 4

- 1 Cooling unit
- 2 Power supply unit
- 3 Actuation board
- 4 Loading switch
- 5 Slider motors
- 6 Slider opening microswitch
- 7 Slider guide assemblies
- 8 Loading buttons

LOADING SWITCH

The loading microswitch is fitted on the lower right-hand side of the door.

When the door is open, the drum rotation buttons are enabled for loading.

The message "Loading with the door open" is indicated on the display and dispensing is disabled.

PROGRAMMING SWITCH

When opening the payment system compartment door the programming switch is triggered.

The message "Loading" is indicated on the display and the selection buttons are assigned programming functions.

This allows programming and/or loading operations to be carried out with the refrigerated box door closed.

The vending cycle is disabled.

IMPORTANT NOTICE!!

The loading and programming switches DO NOT disconnect the power supply from the machine.

To switch the machine off the main switch must be used and the plug must be pulled out.

All operations which require the machine to be energised and the protective casings removed must be carried out by qualified personnel, informed about the specific risks of such condition.

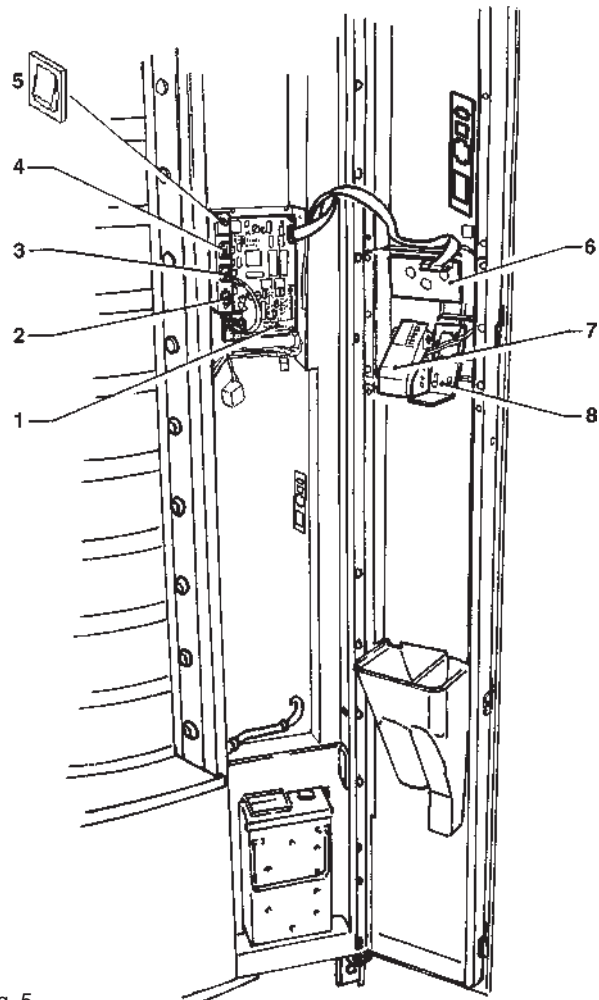

Fig. 5

- 1 CPU board
- 2 RS 232 serial port
- 3 Programming access button
- 4 Failure reset button
- 5 Programming switch
- 6 Liquid crystal display
- 7 Coin chute
- 8 Coin return lever

HYGIENE AND CLEANING

According to current health and safety regulations, the vending machine operator is responsible for its hygiene and maintenance.

It is advisable to use sanitising products (chlorine based detergent or similar) to clean all surfaces even if not in direct contact with food.

Some parts of the machine can be damaged by strong detergents.

Do not use any soaked cloth to clean motors, lighting lamps, loading buttons or the front cover of the power supply unit (see Fig. 4).

The manufacturer declines all responsibility for damage caused by noncompliance with the above instructions or by the use of strong or toxic chemical agents.

Under no circumstances should sprayed water be used.

Always disconnect the machine from the power supply grid before any cleaning operations.

The integrity of the machine and compliance with the standards of the relevant systems must be checked at least once a year by qualified personnel.

LOADING PRODUCTS

Important notice!!!

Products must be hermetically sealed.

When starting the machine for the first time, before loading the refrigerated products it is necessary to switch the power on and then wait until the normal operating temperature is reached (up to 3 hours of pull-down time).

Before loading, it is necessary to check that the internal temperature of the machine is lower than 5°C.

Before refilling the machine **check that the expiry date** of any unsold products has not been exceeded.

The machine control system allows storage of the number of days to the expiry date for each disk sector; and after this is exceeded the sector is considered empty and therefore the product not to be sold.

When opening the front or rear door (on models where it is fitted), the relevant loading buttons are enabled.

Pressing one of loading buttons will cause the corresponding drum to rotate, bringing each sector into loading position.

The drum will be considered completely full and the counting of days to the expiry date for the sectors of that drum will be reset.

Special attention must be paid to the dispensing mode setting for the drum being loaded, if programmed for "shopper" it will be possible to leave some sectors empty, if programmed for F.I.F.O. it will be necessary to fill all sectors.

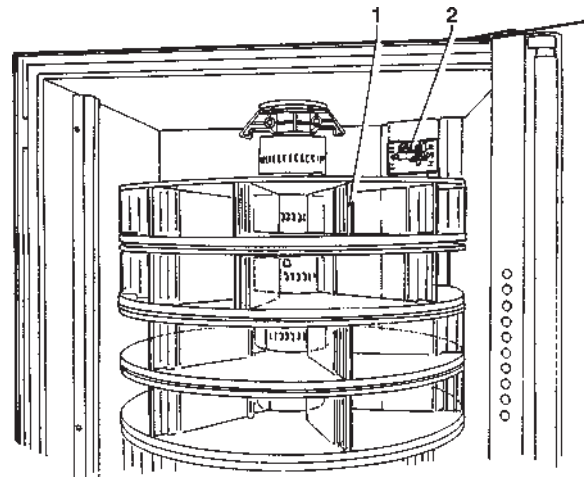

Fig. 6

- | | |
|---|--------------------------|
| 1 | Partitions |
| 2 | Partition counting lever |

For loading, the instructions indicated on the inside of the door must be followed, particularly ensuring that:

- **no items of refrigerated food** with a temperature above **5°C** are inserted, and that all spaces are filled;
- the bottom of the products rest at the bottom of the compartment with the label facing the window so that they can be identified;
- the product packaging does not interfere with the partition counter lever.

LOADING WITH THE DOOR CLOSED

If only few products are to be loaded, it might be convenient to insert them into the machine through the dispensing sliders without opening the door, thus ensuring that the products already in the machine stay cold.

By opening the payment system compartment door, the machine goes into manual loading mode and the number of empty sectors, or with expired products, for each drum is indicated on the price display.

When pressing the selection button, the first empty/expired sector is presented and the slider opens so that the product can be inserted.

Then, when pressing the selection button again, the next sector is presented for filling or the slider closes if the drum is full.

Loading operations for a drum can be interrupted by pressing the button of another selection.

All loading operations must however be carried out as quickly as possible, to avoid that the temperature of products exceeds the safety temperature.

NOISE LEVEL

The continuous, weighted equivalent acoustic pressure level is below 70 dB.

ROUTINE MAINTENANCE

Before carrying out any cleaning or maintenance operations, disconnect the machine from the mains power supply.

Under no circumstances should sprayed water be used to wash the machine.

PERIODICAL CLEANING

Clean metal parts with lukewarm water and mild detergent, then rinse thoroughly and wipe dry carefully.

When cleaning metal parts do not use detergents containing abrasive or corrosive agents; do not use common steel wool, wire brushes or steel scrapers.

Switch off the machine in the event of failure or malfunction. Any repairs should be carried out exclusively by qualified personnel using original spare parts only.

SUSPENDING FROM USE

For long periods of inactivity the following recommendations should be observed:

- disconnect the plug from the power outlet;
- remove all products from the drums and clean the inside and all accessories;
- using a cloth lightly damp with Vaseline oil, apply a protective film on all metal surfaces.

Chapter 2 INSTALLATION

Installation and the following maintenance operations should be carried out with the **machine switched on** and therefore by qualified personnel only, who are trained in the correct use of the machine and informed about the specific risks of such situation.

The machine is not suitable for outdoor installation, it must be installed in a dry room where the temperature remains between 5°C and 32°C.

It cannot be positioned where water jets are used for cleaning (e.g. in large kitchens, etc.).

The machine should be positioned with a maximum inclination of 2°.

UNPACKING THE VENDING MACHINE

After removing the packing, ensure that the machine is intact.

If the vending machine is found to be damaged, immediately inform the carrier and do not use the machine.

No packing elements (i.e. plastic bags, polystyrene foam, nails, etc.) should be left within the reach of children, as they are potentially dangerous.

Packing materials must be disposed of in authorised containers and the recyclable ones must be recovered by qualified companies.

CONNECTING THE MACHINE TO THE POWER SUPPLY

The machine is designed to operate under single-phase 230 V~ voltage and is protected by 15 A fuses. Before making the connection, ensure that the rating corresponds to that of the power grid, and more specifically:

- the supply voltage rating must be within the range recommended for the connection points;
- the main switch should be capable of withstanding the peak load required, and at the same time ensure proper omnipolar disconnection from the power grid with an opening gap of the contacts of at least 3 mm.

The switch, the power outlet and the plug must be located in an easily accessible position.

The electrical safety of the machine is ensured only when it is correctly earthed according to the safety standards in force.

This fundamental safety requirement must be duly verified, and if in doubt the system must be carefully tested by qualified technicians.

The power supply cable is of the type with a fixed plug. Any replacement of the power cable (see figure) should be made by qualified and suitably trained personnel only using cables type HO5 RN - F or HO5 V V-F or H07 RN-F with a 3x1-1.5 mm² section.

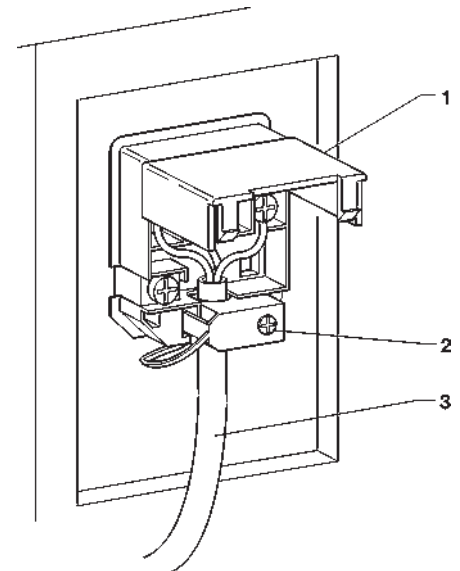

Fig. 7

- 1 - Power supply cable
- 2 - Cable clamp
- 3 - Lift cover

Do not use adapters, multiple sockets and/or extensions.

THE MANUFACTURER DECLINES ALL RESPONSIBILITY FOR ANY DAMAGE CAUSED BY NONCOMPLIANCE WITH THE ABOVE MENTIONED PRECAUTIONS.

INSTALLING THE PAYMENT SYSTEM

The machine is sold without payment system, therefore the installer of such a system is responsible for any damage to the machine or to things and persons caused by faulty installation.

- Install the desired coin mechanism according to the appropriate instructions and make sure that the relevant parameters are programmed correctly.
- adjust the selector opening lever bracket to allow complete opening of the selector;
- adjust the coin chute according to the type of coin mechanism installed.

OPERATING MODES

The vending machines in this range have four different function levels, and namely:

- normal operation;
- loading;
- filler menu;
- technician menu.

According to the operating mode, the display and keypad functions change as described in the following paragraphs.

USER INTERFACE

The interaction between system and user occurs through the following components:

- Button , used to rotate those drums that are programmed for "Shopper" mode or, with the door open, all drums.
- Liquid crystal display (LCD) 4 lines of 20 characters.
- The first four selection buttons, which in maintenance and programming mode have the following functions (see Fig. 8):

Scrolling buttons "↑" and "↓":

To move to the next or previous menu option.

Confirm button "↵":

To move from a menu to a sub-menu or it is used to confirm the current information on the display.

Exit button "←":

To move back from a sub-menu to the higher level menu, or used to cancel the current information on the display.

Programming button "⏏":

(See Fig. 5) To move back from a sub-menu requiring the use of selection buttons to the higher level menu.

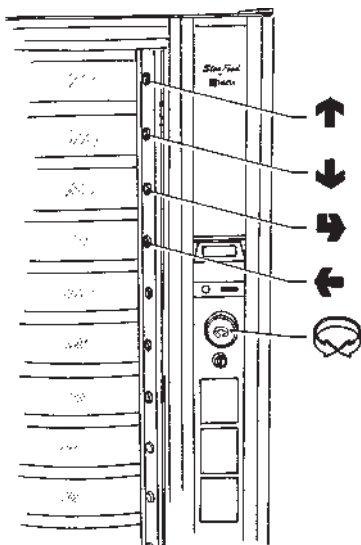



Fig. 8

NORMAL OPERATING MODE

The machine is preset to "Normal operation" mode when connected to the power supply with the door closed (see programming switch).

The lighting lamps are switched on and the product dispensing messages are indicated on the display, as well as other information like temperature and time or details of any current failures.

When pressing button  the drums programmed for "shopper" mode will rotate until the button is released.

If there is sufficient credit, when pressing a selection button the corresponding slider, driven by the motor, opens automatically to the slider stop.

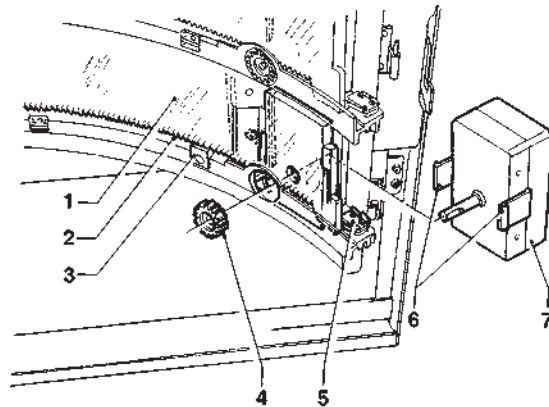

Fig. 9

- 1 - Product slider
- 2 - Rack
- 3 - Slider stop
- 4 - Cog wheel
- 5 - Slider microswitch
- 6 - Motor snap tangs
- 7 - Slider motor

The control system detects the increase in electrical absorption of the motor and stops it for a programmable time (10 seconds by default).

After this time lapses, the motor starts closing the slider. During the closing phase the slider can be opened again by pressing a selection button:

Should the slider be obstructed in some way, four consecutive closing attempts will be made before disabling the machine.

For the following 10 minutes the closing attempts will be repeated every 60 seconds.

The closing attempts are indicated by a sound and on the display.

Each drum is monitored by a device which counts the sectors with sold products, so that the empty drums are identified, as well as allowing or preventing the rotation by means of a magnet.

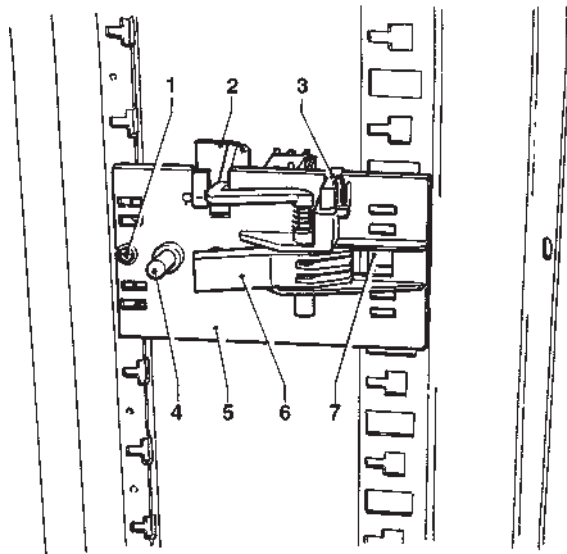

Fig. 10

- 1 - Securing screw
- 2 - Sector counting lever
- 3 - Home point magnet sensor
- 4 - Stop magnet pin
- 5 - Drum monitoring device
- 6 - Anti-rotation lever
- 7 - Quick snap hook

Counting is by means of a lever, operated by the passage of partitions.

A sensor detects the passage of a magnet, located on the edge of each drum, identifying the home point.

LOADING

With the door open

A special switch (see Fig. 4) signals to the control system that the door is open.

The loading buttons are activated and product vending is disabled.

When pressing a loading button, the corresponding drum rotates, to allow refilling, until the button is released.

As soon as it is operated, the drum is considered completely full and the counter of number of days to the expiry date for that drum is reset.

With the door closed

In order to avoid a temperature increase inside the refrigerated box, the products can be loaded through the dispensing sliders.

The machine is preset for loading with the door closed (release of a single slider) by opening the payment system compartment door; the number of empty sectors is indicated on the price display of each drum.

When pressing the selection button, the first empty/expired sector is presented and the slider opens so that the product can be inserted.

Then, when pressing the selection button again, the next sector is presented for filling or the slider closes if the drum is full.

Loading operations for a disk can be interrupted by pressing the button of another selection.

AUTO-CONFIGURATION

If the machine is disconnected from the mains power supply by unplugging the cable or using the main switch (see Fig. 20), when restarting the machine will go through an auto-configuration cycle.

The drums will be rotated at least a full turn, then the number of detected compartments for each drum and the position of the home point magnet will be stored.

FILLER MENU

The machine is preset to “filler menu” mode when the payment system compartment door is opened and the programming button is pressed (see Fig. 5).

The keys “↑” and “↓” scroll through the menu items, which include:

“Statistics”	Data reading
“Prices”	Changing the price for one selection
“Tubes control”	Manual refill and release of change tubes
“Air adjustment”	Movement of stack and drums to align the air flow regulators
“Anti-tampering”	Checking if the sold compartments contain objects
“Test”	activating the drums; activating the sliders; test dispensing for each drum.

STATISTICS

Data on the machine operations is stored in both general counters and relative counters, which can be reset without losing total data.

PRINT

Connect an RS232 serial printer having a Baud rate of 9600, 8 data bit, no parity, 1 stop bit to the serial port located on the push button board to print all of the statistics, and namely:

Total

- 1 - counter by single selection;
- 2 - counter by time bands;
- 3 - failure counter;
- 4 - coin mechanism data.

Relative

- 1 - counter by single selection;
- 2 - counter by time bands;
- 3 - failure counter;
- 4 - coin mechanism data.

The printout will also contain the machine code, the date and the software version.

To connect the printer, do as follows:

- press the confirm print button “↵”, displaying the message “Confirm?”;
- connect the printer before confirming;
- press the confirm button “↵” to start printing.

DISPLAY

When pressing the confirm button “↵” the data described in the paragraph “Printing the statistics” is sequentially displayed.

RESET

Statistics can be reset for relative counters globally (all types of data) or selectively for:

- selections
- failures
- coin mechanism data

Press the confirm button “↵”, and the message “Confirm?” starts blinking.

Press the confirm button “↵”, the message “Working” is displayed for a few seconds and all statistics are reset.

SELECTION PRICES

This function is used to change the sales price for all compartments of a drum, for time band 0 and for all days of the week.

CHANGE TUBES CONTROL

By accessing the “Tube control” function the change tubes can be filled or released manually.

Confirm refilling, and the display will indicate “Credit: —” which is the value of money available in change the tubes; insert the desired coin into the selector and the display will indicate the value of money available in the change tubes.

When confirming releasing, it will be possible to decide which tube to release. Each time the confirm button “↵” is pressed, a coin is ejected from the active tube.

ADJUSTING THE AIRFLOW

The cold air flow coming from the central stack can be adjusted for each drum by means of the special adjustment screw. In order to make any adjustment the screws must be aligned with the corresponding holes on the drums.

With this function the entire stack can be rotated by pressing a loading button, until the screws are positioned in front of the operator.

It is also possible to unlock a single drum to be rotated manually until the hole is aligned with the adjustment screw.

ANTI-TAMPERING CHECK

This function is used to align to vending position the compartments recognised as empty by the machine control software to visually check that no products were accidentally left.

TEST

DRUM TEST

With this function the correct functioning of the drum rotation can be tested by pressing the selection buttons. With these function, pressing the loading buttons **does not change the status** of a drum and/or of a sector (full/empty/expired).

SLIDER TEST

With this function the correct functioning of the sliders can be tested by pressing the selection buttons without rotating the drums.

With these function, pressing the loading buttons **does not change the status** of a drum and/or of a sector (full/empty/expired).

COMPLETE SELECTIONS

Normal product dispensing can be simulated without inserting any money.

With this function, pressing the selection button **changes the status** of a drum and/or of a sector (full/empty/expired).

GSM PRE-ALARMS

The control software can send, via GSM modem, a signal indicating an “ending product” signal, when there is only a certain (programmable) number of pieces or grams of powder of a given product left. With this function the counters that control the pre-alarms are reset.

EVADTS TRANSFER



When activating this function, the machine awaits the connection with a device to acquire the EVADTS statistics.

TECHNICIAN MENU

Using the programming procedures described in this section, it is possible to set all variables regarding machine configuration.

The machine is preset to “technician menu” mode when connected to the power supply with the payment system door open and the programming button is pressed twice.

N.B. When pressing the button again while in the programming menu, the machine will return to “loading” mode.

The keys “” and “” scroll through the technician menu items, which include:

Failures	Reading present failures		
	Reading drum/slider failures		
Lighting	Delete		
	Lamps On/Off with out of service		
Prog. parameters	Cash	Prices Coin mech. Decimal point Bonus	
	Drums/sliders	Drum parameters Slider parameters	
	Cold parameters	Temperature Defrosting Air adjustment Cooling unit	
	Display	Language User messages Promotional message Personal. strings Euro Display counters	
	Miscellaneous	Password Energy saving Progr. level	
	Statistics	Print	Partial Total
		Print relative	Partial Total
		Display	Selections Time bands Failures Coin mech.
		Display relative	Selections Time bands Failures Coin mech.

Delete	Partial Total
Cancel relative	Partial Total
Test	Drum Slider Complete selection
Miscellaneous	Machine info Installation date Machine code Operator code
	Initialising
GSM	Pin code Pre-alarms
EVADTS	Pass code Security code Connection

PRESENT FAILURES

READING

When the “Failure” function is displayed, press the confirm button “” to display the present failures.

If no failures are currently present, after pressing the confirm button “” the message “End failures” will be displayed.

The monitored failures are:

Compressor

The machine is locked if the compressor runs nonstop for more than 24 hours.

Coin mechanism

The machine is locked if it receives a pulse longer than 2 seconds on a validator line or the communication with the serial coin mechanism does not take place for more than 30 seconds (Executive protocol) or 75 seconds (BDV protocol).

RAM Data

One or more areas of the RAM contain wrong data which was corrected with the default values.

The machine will continue to function, but it would be advisable to initialise as soon as possible.

Probe

The machine is locked after 5 minutes if the internal temperature sensor is disconnected; the display will indicate a temperature of -11° C.

The machine is locked after one hour if a sensor short circuit is detected; in this case the display will indicate a temperature of +41° C.

Machine control board

Failed dialogue between C.P.U. board and machine control board.

Gas temperature sensor

The display will indicate the message if a short-circuit is detected on the temperature control sensor of the hot-gas evaporator.

DISPLAYING DRUMS / SLIDERS

Slider failure

If the motor electrical absorption is absent or above the programmed threshold, power is disconnected from the motor and the selection is disabled.

Slider open

If the microswitch does not return to normal position within 3 attempts of 10 seconds after opening the slider, the machine is set out of service.

10 more closing attempts are made at 60 second intervals.

Drum failure

If the "home" point magnet is not detected after a complete drum rotation, or if a microswitch does not detect the passage of the partition after making a selection, the selection is disabled.

RESET

By confirming this function all current failures will be reset

EXTERNAL LIGHTING

Setting whether or not the lighting lamps in the external panels are to be switched on when the machine is out of service or during the "Energy saving" time band.

PROGRAMMING THE PARAMETERS

CASH

This set of functions controls all parameters regarding the payment systems and the sales prices.

SELECTION PRICES

Four different prices can be set for each selection, and for each day of the week, programmed according to the time bands, if enabled.

For each of the 4 time bands prices (0 to 65,535) can be programmed globally (same price for all selections) or for the single selections.

Should the majority of products be sold at the same price, it will be convenient to set the price globally and then change the figure of the selections with different prices.

TIME BANDS

Four programmable time bands are provided for selling products at different prices.

The time periods are programmable for beginning and end time by hours (00 to 23) and minutes (00 to 59).

If the values for start and end of the time band are set to 00.00 the time period is disabled.

The reference time is kept by an internal clock, programmable as:

day/month/year weekday 1-7

and then

hour/minutes/seconds.

COIN MECHANISMS

It is possible to decide which of the payment system protocols available are to be enabled for the functions.

The available payment systems are:

- Executive

- Validators

- BDV

- MDB

By selecting one of the systems it is possible to control its functions.

EXECUTIVE

The following payments systems are available for the Executive system:

- Standard

- Price Holding

- Coges

- U-Key

VALIDATORS

When the "Validat. Lines" (line setting) function of the "technician" menu is displayed, the value of the 6 validator coin lines, A to F, can be changed.

BDV

The BDV protocol menus are used for defining the following functions:

Type of vending

Setting the operating mode for multiple or single dispensing. With multiple dispensing, the change is not automatically returned after a successful selection, however the credit is available for further selections. When pressing the coin return button, the available credit is returned if its value is lower than the maximum change value.

Change control

This function enables/disables the return of credit if no selections are made.

If enabled, this function allows the return of coins even if the first selection was not dispensed.

If however a selection fails for any reason, the change will be returned if requested.

Maximum credit

This function is used to define the maximum accepted credit.

Maximum change

It is possible to set a limit to the total amount of change returned by the coin mechanism when pressing the coin return button or after a single dispensing serving.

Any credit exceeding the amount programmed with this function will be cashed.

Accepted coins

It is possible to define which, among the coins recognised by the validator, are to be accepted.

Check the label on the coin mechanism for the correct coin to value matching, indicating the position of the coins.

Not accepted coins

This function programs the rejection of coins when in “exact amount” mode.

Check the label on the coin mechanism for the correct coin to value matching, indicating the position of the coins.

Dispensing buttons

This function enables or not the buttons on the coin mechanism used to release the coins in the change return tubes.

Value of “exact amount”

This value defines the combination of empty coin tubes, setting the coin mechanism in “exact amount” mode. The possible combinations of empty coin tubes are indicated below.

For greater simplicity, the combination is described with reference to tubes A, B and C, where tube A receives the lower value coins and tube C the greater value coins.

0	=	A or (B and C)
1	=	A and B and C
2	=	A and B only
3	=	A and (B or C)
4	=	A only
5	=	A or B (default) only
6	=	A or B or C
7	=	A or B only
8	=	A or C only
9	=	B and C only
10	=	B only
11	=	B or C only
12	=	C only

C.P.C. device

It dialogues with the coin mechanism if devices are installed or removed from the serial interface (C.P.C.-type devices - the monitoring unit is always enabled by default).

Minimum level of tubes

It brings forward the “Insert exact amount” message for the user, by adding a number of coins between 0 and 15 to the programmed number of coins, to set the “full change tubes” status.

Free Vend VMC

Most payment systems with the BDV protocol control the free vend function.

However, there are some payment systems without such function.

In this case, if free selections are to be dispensed, free vending must be enabled with VMC (vending machine control, enabled by default) and the price of the selections must be set to zero.

MDB

The MDB protocol menus are used for defining the following functions:

Type of vending

Setting the operating mode for multiple or single dispensing. With multiple dispensing, the change is not automatically returned after a successful selection, however the credit is available for further selections. When pressing the coin return button (if the function is enabled), the available credit is returned up to the maximum change value.

Change control

To enable/disable the operation of the coin return button.

Maximum credit

This function is used to define the maximum accepted credit.

Maximum change

It is possible to set a limit to the total amount of change returned by the coin mechanism when pressing the coin return button or after a single dispensing serving.

Any credit exceeding the amount programmed with this function will be cashed.

Accepted coins

It is possible to define which, among the coins recognised by the validator, are to be accepted when the change tubes are full.

Check the coin mechanism configuration for the correct coin to value matching.

Returned coins

It is possible to define which, among the coins available in the tubes, are to be used for returning the change. This parameter is active only with coin mechanisms that do not automatically control the choice of tube to be used (Auto changer payout).

Check the coin mechanism configuration for the correct coin to value matching.

Accepted bills

It is possible to define which, among the bills recognised by the reader, are to be accepted.

Check the reader configuration for the correct bill to value matching.

Minimum level of tubes

This function is used for setting the number of coins (0 to 15) to determine the status of full change tubes and the “Insert exact amount” message for the user.

Accepted coins with “exact amount”

It is possible to define which, among the coins recognised by the validator, are to be accepted when the machine is in the “exact amount” condition.

Check the coin mechanism configuration for the correct coin to value matching.

COMMON FUNCTIONS

Other menus are available, common to the three protocols, used for defining the following functions:

IMMEDIATE CHANGE

Normally, the amount of credit inserted for a selection is cashed after the machine sends the message "Selection successful".

When this function is enabled, disabled by default, the cash message is sent at the beginning of dispensing.

DECIMAL POINT

Press the confirm button "↵" to display the position of the decimal point, i.e.:

0	decimal point disabled
1	XXX.X
2	XX.XX
3	X.XXX

Press the confirm button "↵", these values will start blinking and can then be modified as necessary.

FREE VEND BONUS

This function, compatibly with the national laws, permits the dispensing of a free product every certain programmable number of sold selections. In any case the free selection is random within the programmed number. The machine emits an intermittent sound signal and the display indicates a congratulations message.

DRUMS / SLIDERS

This set of functions is used to define the control parameters of the different drums and sliders.

DRUM VENDING PARAMETERS

The programmable drum parameters are as follows:

Type of vending

Setting the vending mode (Shopper or First In - First Out) for each drum;

Drum status

Enabling or disabling a drum for vending

Drum status by time band

Enabling or disabling a drum for vending according to the programmed time bands.

Drum expiry date

Setting the number of days from the last refill after which the sectors are considered expired (vending disabled).

The counter is reset for all sectors of a drum at each refill. With the number of days to expiry date set to zero (default) this function is disabled.

Drum rotation

Setting the amount of time between the slider closing and the moment when the drum rotation can start.

During this time the slider can be reopened.

Drum codes

A four-digit code can be assigned to each drum, identifying the drum when processing the statistical data.

SLIDER PARAMETERS

Slider opening time

Setting the amount of time for slider opening (10 sec. by default).

COLD PARAMETERS

The operation of the refrigeration system can be programmed for the following functions.

TEMPERATURE

Internal temperature

The internal temperature of the machine during normal operation can be set directly in °C (3 to 25); the default setting is 3° C.

Safety temperature

This function enables the control over the temperature (4° C higher than the rated internal temperature) to be reached within 45 minutes from switching the machine on, from closing the door or after 15 minutes of normal operation. When this function is active, if the temperature is not reached the machine is locked.

Temperature log

The internal temperature is stored every 10 minutes. With this function, it is possible to read the date, time and stored temperature.

DEFROSTING

Automatic defrosting (with hot gas)

This function allows for a defrosting cycle (flow of hot gas to the evaporator) of 10 minutes maximum. The time interval between cycles can be programmed from 0 to 99 hours (the default setting is 6 hours); the time interval will be determined according to the relative ambient humidity and to the frequency of door openings.

With the timing set to 0 the function is disabled.

Defrosting cycle log

The duration in minutes of every defrosting cycle is stored. With this function, it is possible to read the date, time and stored duration.

ADJUSTING THE AIRFLOW

The cold air flow coming from the central stack can be adjusted for each drum by means of the special adjustment screw. In order to make any adjustment the screws must be aligned with the corresponding holes on the drums.

With this function the entire stack can be rotated by pressing a loading button, until the screws are positioned in front of the operator.

It is also possible to unlock a single drum to be rotated manually until the hole is aligned with the adjustment screw.

ENABLE COLD UNIT

The cooling unit operation can be disabled. The change will apply when restarting the machine.

DISPLAY

This set of functions is used to manage the messages indicated on the external display.

LANGUAGE

There is a choice of language, selected among the ones included in the EPROM, to be used for the messages on the display.

DISPLAYING MESSAGES FOR THE USER

It is possible to choose the kind of information to be indicated on the display during normal operation.

The following information can be displayed:

- No information
- Internal temperature
- Date and time

It is possible to choose the language for the displayed messages.

PROMOTIONAL MESSAGE

Enable

When in this menu, press the confirm button "↵" to display the status of the message (enabled or disabled). The status can then be changed using the "↑" and "↓" buttons.

Setting

The 4-line message can be written using the "↑" and "↓" buttons to scroll through the available characters.

Press the confirm button "↵", the first character will start blinking and can be modified.

The message is stored by pressing button "↵".

PERSONALISING THE MESSAGES

The machine uses standard messages to give information to the user during normal operation (e.g. "Ready", "Take" etc.). When this function is enabled, the message can be changed in the same manner as setting the promotional message. Changes are stored as copies of the standard messages.

Therefore, if this function is disabled, the standard messages will be displayed again, but the changed messages are still stored.

EURO

It is possible to decide whether the selection prices are to be displayed in Euro, the local currency or both.

DISPLAY THE SELECTION COUNTERS

This function is used to enable/disable the display of the total number of sales since the last statistic reset, during the start-up phase of the machine.

MISCELLANEOUS

This set of functions contains some sub-menus, used less frequently, which permit control of the functions described below.

PASSWORD

Entering the password

It is a 5-digit numeric code which is required to access programming.

The default value of this code is set to 00000.

Enabling the password

This function is used to enable the option of requesting the password to access programming; the password request is disabled by default.

ENERGY SAVING

In order to save electric energy when the machine is not in use, this function is used to switch off the external lighting.

2 switch-off time bands can be programmed on a weekly basis; the week days are identified by a progressive number (1=Monday, 2=Tuesday etc.).

The same time band cannot include days from different weeks.

If time bands are set overlapping, the machine will remain switched on for the shorter period.

For example, in order to set energy saving time bands to run the vending machine from 07.00 to 22.00 during the week and leave it switched off on the weekend, the time bands should be set, using the special menu, as indicated in the table below.

Day		1	2	3	4	5	6	7
band 1	start	00.00	00.00	00.00	00.00	00.00	00.00	00.00
	end	07.00	07.00	07.00	07.00	07.00	23.59	23.59
band 2	start	22.00	22.00	22.00	22.00	22.00	00.00	00.00
	end	23.59	23.59	23.59	23.59	23.59	00.00	00.00

DISPLAYING THE FILLER MENU

This function is used to determine the filler menu options to be left active or to be disabled.

The reference numbers of the menus do not change even if some are disabled.

STATISTICS

Data on the machine operations is stored in both general counters and relative counters, which can be reset without losing total data.

PRINT

Connect an RS232 serial printer having a Baud rate of 9600, 8 data bit, no parity, 1 stop bit to the serial port located on the push button board to print all of the statistics, and namely:

Total

- 1 - counter by single selection;
- 2 - counter by time bands;
- 3 - failure counter;
- 4 - coin mechanism data;



Relative

- 1 - counter by single selection;
- 2 - counter by time bands;
- 3 - failure counter;
- 4 - coin mechanism data;

The hardcopy printout will also contain the machine information, and namely:

- date/time of print
- machine name
- software version
- operator code
- machine code
- Installation date.

To connect the printer, do as follows:

- press the confirm print button “”, displaying the message “Confirm?”;
- connect the printer before confirming;
- press the confirm button “” to start printing.

DISPLAY

When pressing the confirm button “” the data described in the paragraph “Printing the statistics” is sequentially displayed.

RESETTING THE STATISTICS

Statistics can be reset for counters globally (all types of data) or selectively for:

Total

- selections
- failures
- coin mechanism data

Relative

- selections
- failures
- coin mechanism data

Press the confirm button “”, and the message “Confirm?” starts blinking.

Press the confirm button “”, the message “Working” is displayed for a few seconds and all statistics are reset.

N.B.: when resetting the total statistics also the relative statistics are reset.

BDV protocol Audit

The information regarding the coin mechanism indicates the actual currency of:

Audit 1 Money in the tubes

Money present in the change tube that moment

Audit 2 Money to the tubes

Money sent to the change tubes

Audit 3 Money to the box

Money sent to the coin box

Audit 4 Return of change

Total money returned

Audit 5 Dispensed money

Total money dispensed manually

Audit 6 Excess

Excess money. Extra amounts paid by the customer that were not returned (in the event there was no money available for return)

Audit 7 Total sales

Total value of sales

Audit 8 Exact change

Value of sales in the "no change" condition.

Audit 9 Mixed dispensing

Total value of dispensing paid differently; for example also other types of payment (C.P.C., token).

Audit 10 Manual loading

Money inserted in the coin mechanism through the manual filling function.

MDB protocol Audit

Audit 1 Money in the tubes

Money present in the change tubes that moment

Audit 2 Money to the tubes

Money sent to the change tubes

Audit 3 Money to the box

Money sent to the coin box

Audit 4 Change return

Total money returned

Audit 5 Excess

Excess money. Extra amounts paid by the customer that were not returned (in the event there was no money available for return)

Audit 6 Release tubes

Value of coins dispensed with the "Tubes control" function

Audit 7 Loading tubes

Value of money cashed with the manual loading function

Audit 8 Cash sales

Value of total sales with cash money (coins + bills)

Audit 9 Cashed bills

Value of cashed bills

Audit 10 Charge key

Value of money changed into the key

Audit 11 Sales with key

Value of money cashed for dispensing with key

Audit 12 Money dispensed manually

Value of coins dispensed manually with the dispensing buttons on the coin mechanism.

TEST

DRUM TEST

With this function the correct functioning of the drum rotation can be tested by pressing the loading buttons. With these function, pressing the loading buttons **does not change the status** of a drum and/or of a sector (full/empty/expired).

SLIDER TEST

With this function the correct functioning of the sliders can be tested by pressing the loading buttons without rotating the drums.

With these function, pressing the loading buttons **does not change the status** of a drum and/or of a sector (full/empty/expired).

COMPLETE SELECTIONS

Normal product dispensing can be simulated without inserting any money.

With this function, pressing the selection button **changes the status** of a drum and/or of a sector (full/empty/expired).

MISCELLANEOUS

This menu contains some sub-menus, used less frequently, which permit control of the functions described below.

MACHINE INFORMATION

The machine can memorize a series of codes which will identify it when retrieving statistics.

More specifically the following can be stored:

- The 6-digit operator code which also represents the password to access code change mode;
- 8-digit vending machine code which identifies the machine.

INSTALLATION DATE

This function is used to store the current date of system as installation date.

The date is printed when retrieving the statistics.

MACHINE CODE

When the "Machine code" function is displayed the eight-digit numeric code identifying the machine can be changed (from the default 0).

OPERATOR CODE

When the "Operator code" function is displayed the six-digit numeric code identifying groups of machines can be changed (from the default 0).

INITIALISING

When the "Initialise" function is displayed the vending machine can be initialised restoring all default data.

This function should be used if there is a memory data error or when the EPROM is replaced.

All statistic information will be reset.

Press confirm button "↵" and the display will indicate the message "Confirm?". Press confirm button "↵" a second time and the message "Working" is displayed for a few seconds.

GSM

The control software can send, via GSM modem, a signal indicating a machine failure or an “ending product” “pre-alarm”, after dispensing a certain (programmable) number or quantity of a given product.

The machine fitted with the modem can have the function of “master GSM”, i.e. collect and transmit data from other banked machines.

PIN CODE

This function is used for programming the identification code of the SIM card (0000 by default) that will be sent to the GSM modem (optional) when switching the machine on.

SETTING THE THRESHOLDS

This function is used for defining the number of pieces or grams of powder for a given product, after which a “running-out” “pre-alarm” is signalled via modem.

RESETTING THE COUNTERS

With this function the counters that control the pre-alarms are reset.



When pressing the confirm button “” the values are reset.

EVADTS CODES

The EVADTS (European Vending Association Data Transfer System) communication protocol has two codes for identifying the machine and for recognising the data transfer terminal:

PASS CODE

It is a four-digit alphanumeric code (0-9; A-F) that must be the same as the one in the data transfer terminal to allow its identification.

Press the confirm button “” and the code is displayed as “0000” regardless of the actual value; then press the correction button “” and the first digit will start blinking. Using the scrolling buttons, its value can be changed (during the change operation the value becomes visible). Press the change button “” and the next digit starts blinking.

Press the confirm button “” after changing the fourth digit; the value is stored and the display indicates “0000” again.

SECURITY CODE

It is a further alphanumeric code for reciprocal recognition between machine and EVADTS terminal. Programming works as in the “Pass” code.

EVADTS CONNECTION

When activating this function, the machine awaits the connection with a device to acquire the EVADTS statistics.

PRINTED BOARD FUNCTIONS AND INDICATOR LAMPS

CPU BOARD

The C.P.U. board (Central Processing Unit) is located inside the payment system compartment; it communicates with the machine control board and processes the input signals from the push-buttons, the payment system and controls the display.

The card houses the "Flash EPROM" (the chips that contain the program) and a series of dip-switches (see Fig. 14) permitting the card to be configured according to the use of the machine (see relevant chapter).

The card also houses some LEDs which, during the machine operation, give the following indications:

- green LED (2) blinking during the normal operation of the C.P.U. board
- Yellow LED (3): glows when 5 V DC are detected;
- red LED (4): glows in the event of a program error;
- red LED (5): glows during the card reset.

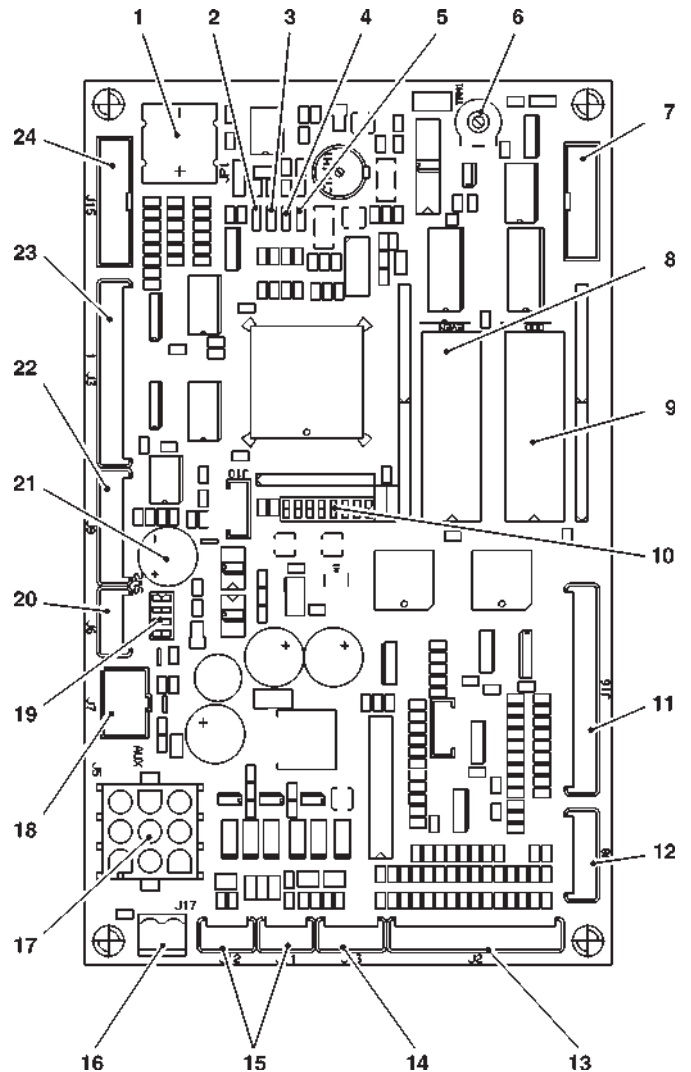

Fig. 11

- | | |
|----|--|
| 1 | - Battery |
| 2 | - Green LED: RUN |
| 3 | - Yellow LED: 5 V DC |
| 4 | - Red LED: program error |
| 5 | - Red LED: board reset |
| 6 | - LCD contrast control trimmer |
| 7 | - LCD connector |
| 8 | - Flash EPROM: EVEN |
| 9 | - Flash EPROM: ODD |
| 10 | - Configuration dip-switches |
| 11 | - Service buttons connector |
| 12 | - Price display connector |
| 13 | - Selection buttons connector |
| 14 | - Connector not used |
| 15 | - Connectors for control board communication |
| 16 | - 24 V DC power supply to board |
| 17 | - BDV connector |
| 18 | - MDB connector |
| 19 | - Coin mechanism setting dip-switches |
| 20 | - Connector not used |
| 21 | - Buzzer |
| 22 | - RS232 connector |
| 23 | - Connector not used |
| 24 | - Validator connector |

ACTUATION BOARD

This board (see Fig. 12) activates, by means of relays, some of the 230V~ components of the machine.

This board is powered with 24 V DC.

The control board Flash EPROM is fitted on this board:

- green LED, blinking at intervals of approximately one second, indicates that the microprocessor is working correctly; if blinking fast it indicates that there is no communication with the CPU card.
- red LED "H1", indicates
- red LED "H2", indicates
- red LED "H2", indicates

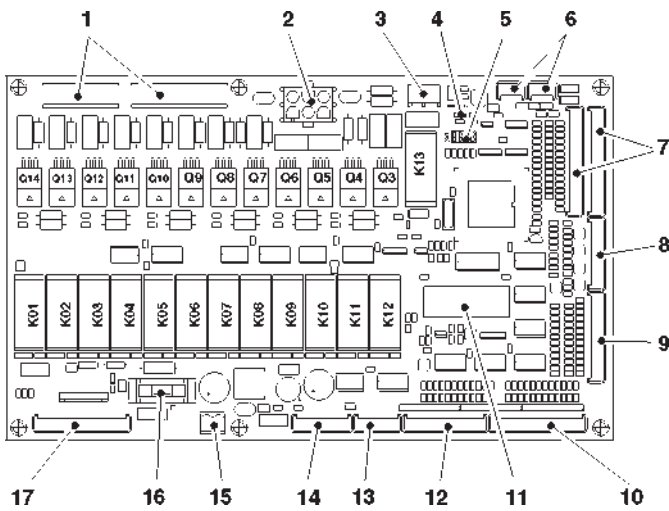

Fig. 12

RELAY AND TRIAC FUNCTION (see Wiring diagram)

K01	=	slider motor 1
K02	=	slider motor 2
K03	=	slider motor 3
K04	=	slider motor 4
K05	=	slider motor 5
K06	=	slider motor 6
K07	=	slider motor 7
K08	=	slider motor 8
K09	=	slider motor 9
K10	=	slider motor 10
K11	=	slider motor 11
K12	=	slider motor 12
K13	=	slider heating elements
Q3	=	disk magnet 1
Q4	=	disk magnet 2
Q5	=	disk magnet 3
Q6	=	disk magnet 4
Q7	=	disk magnet 5
Q8	=	disk magnet 6
Q9	=	disk magnet 7
Q10	=	disk magnet 8
Q11	=	disk magnet 9
Q12	=	disk magnet 10
Q13	=	disk magnet 11
Q14	=	disk magnet 12

CONFIGURING THE C.P.U. BOARD

By using the configuration dip-switches the CPU card can be preset to operate with the different payment systems (dip-switches 1-4) and show the messages on the LCD display in different languages (dip-switches 6-8).

Dip-switch 5 is not used.

The 2 dip-switches for MDB coin mechanism setting (see Fig. 9) must both be set to OFF (Executive).

SOFTWARE UPDATE

The machine is fitted with Flash EPROMs which can be electronically updated.

By means of a special program and suitable system (Personal Computer, palmtop or similar) the machine management software can be updated without replacing the EPROMs.

- | | | |
|----|---|--|
| 1 | - | connection to drum magnets |
| 2 | - | power supply to drum magnets and slider heating elements |
| 3 | - | connection to slider heating elements |
| 4 | - | green LED |
| 5 | - | board configuration dip-switches 1-4: OFF 2-3: ON |
| 6 | - | connection to CPU board |
| 7 | - | connection to internal loading buttons |
| 8 | - | connection to sensors |
| 9 | - | connection to slider closing microswitches |
| 10 | - | connection to microswitches of drum home point |
| 11 | - | EPROM |
| 12 | - | connection to drum sectors microswitches |
| 13 | - | not used |
| 14 | - | connection to 230 VAC user relays |
| 15 | - | 24 V DC power supply |
| 16 | - | slider motor fuses |
| 17 | - | connection to slider motors |

SELF-DIAGNOSIS FUNCTION

A function to check, in a semiautomatic manner, the correct operation of some devices is implemented in the software.

Some checks occur automatically, others need the manual operation of the monitored component; button  is pressed to go to the next check.

The function is activated by setting dip-switch 1 on the CPU board to = ON.

When starting the machine, the display indicates for a few seconds the message "Autotest" and then:

"Shopper button"

Press the Shopper button .

If the connection is correct the message "OK" is indicated on the display together with a sound signal and advance to the next check.

"Display test"

Rectangles are shown on the entire display to check the integrity of all pixels.

Automatic advance to the next check.

"LCD test"

8.8.8.8. is displayed on the sliders' LCDs to check the integrity of all segments.

Automatic advance to the next check.

"Lamp test"

The vending machine lamps are lit for a few seconds.

Automatic advance to the next check.

"Small door microswitch"

By operating the switch on the payment system door the status of 'Closed micro' or 'Open micro' changes.

Press  to advance.

"Programming button"

Press the programming button (see Fig. 5).

If the connection is correct the message "OK" is indicated on the display together with a sound signal and advance to the next check.

This check can be skipped by pressing .

"Reset button"

Press the Reset button (see Fig. 5).

If the connection is correct the message "OK" is indicated on the display together with a sound signal and advance to the next check.

This check can be skipped by pressing .

"Rear door microswitch"

By operating the switch on the rear door (if fitted), the status of 'Closed micro' or 'Open micro' changes.

Press  to advance.

"Large door microswitch"

By operating the switch the status of 'Closed micro' or 'Open micro' changes.

Press  to advance.

"Selection buttons" - "Selection number 01"

Press the first selection button.

If the connection is correct the message "OK" is indicated on the display together with a sound signal and advance to the next selection.

This check can be skipped by pressing  various times.

"Slider test"

By pressing the selection buttons, the corresponding sliders are opened and closed (this operation can be carried out only with the door closed).

If the slider opens and closes correctly the message "OK" is indicated on the display together with a sound signal and advance to the next selection.

The status of the opening microswitch and the closing safety can be checked.

Press  to advance.

"Drum test"

By pressing the loading buttons inside the machine, the corresponding drums are activated.

The rotation causes the sector counter microswitch to trigger, and the passage of the magnet on the relevant sensor.

Press  to advance.

"Compressor test"

The compressor is activated.

After 10 seconds, automatic advance to the next check.

"Compressor fan test"

The compressor fan is activated.

Press  to advance.

"Fan test"

The ventilation fan is activated.

Press  to advance.

"Temperature"

The values of temperature detected by the probes are displayed.

In the event of disconnection the value -11.0 is displayed.

In the event of a short-circuit the value 41.0 is displayed.

Press  to advance.

At the end of the test cycle, switch the machine off and place Dip-switch 1 back to the OFF position.

DRUM MAINTENANCE

DISASSEMBLY AND RE-ASSEMBLY OF THE PRODUCT DRUMS

After opening the quick snaps, the two drum halves can be removed.

Using the loading buttons, the drums must be rotated until the joint line and the locking bolt are visible.

- Insert the special wrench onto the locking bolt and open the quick snap (tension cam) by turning slightly to the left (clockwise).
- Continue rotating the drum 180° and open the next locking bolt.

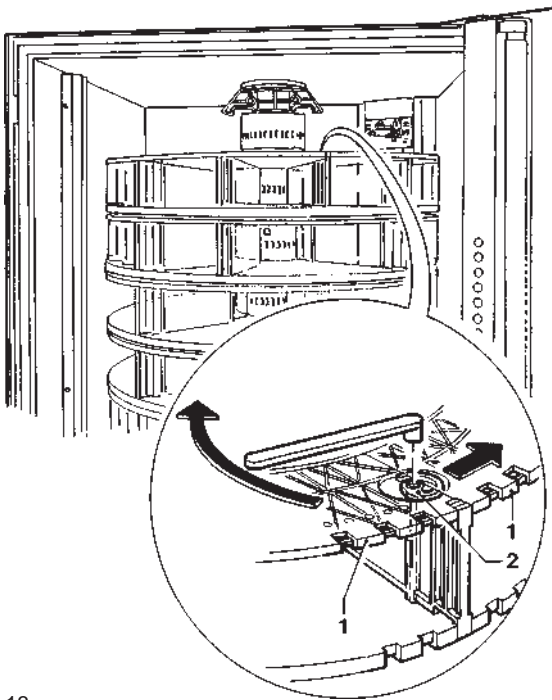

Fig. 13

- 1 - Drums halves
- 2 - Quick snap

- Continue rotating a further 90°.
- Remove the first drum half in small jerks.
- Continue rotating the drum a further 180° and take out in small jerks the second drum half.
- Re-assembly will be done likewise but in the reverse order!

Only those drum halves with exactly the same section partitioning (see Fig. 15) can be assembled.

CHANGING THE COMPARTMENTS OF A DRUM

Each drum can be subdivided into 6, 12, 18, 24 or 36 sectors according to the number and type of partitions used.

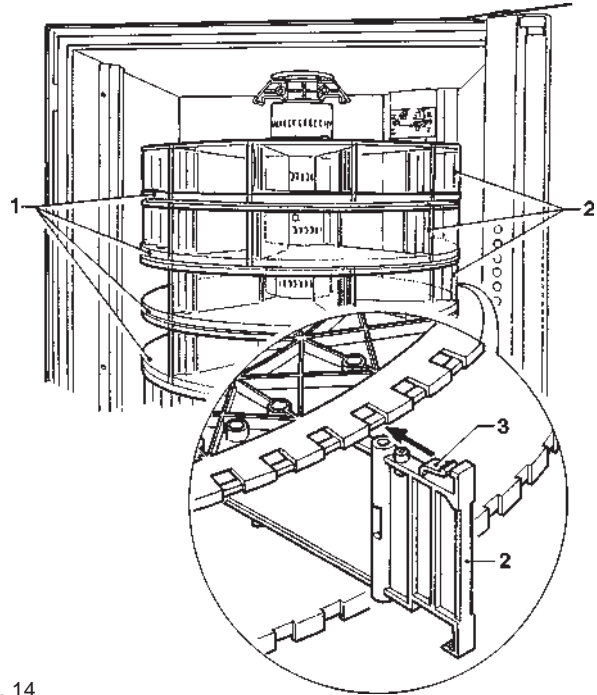

Fig. 14

- 1 - Drums
- 2 - Partitions
- 3 - Locking tangs

A new division of the sectors can be made by inserting the partition walls into the designated slots. Pay attention to the correct locking of the partition locking nose.

Each drum can only be divided into sectors of equal size!

No. of sectors	No. of partitions	No. of free slots
6	6	11
12	12	5
18	18	3
24	24	2
36	36	1

Warning: after each new sector partitioning the machine must be reprogrammed (see programming chapter).

IMPORTANT NOTICE:

After every change to the number of sectors, the stop device (see Fig. 9) on the slider guide must be adjusted again.

Undo the stop screw, using a Phillips screwdriver, and move it to the new position.

SHAPED DIVIDERS

Some models are fitted with drums that have shaped dividers (available also as accessories for later installation) so that rectangular shape products can be accommodated (see Fig. 15).

In this case the number of compartments cannot be changed.

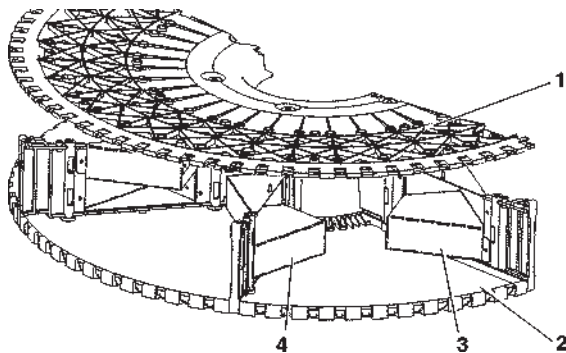

Fig. 15

- 1 - Upper half-disk
- 2 - Lower half-disk
- 3 - Right-hand shaped divider
- 4 - Left-hand shaped divider

PRODUCT SUPPORTS

For some models, 24 supports are supplied with the machine, also available separately; such supports are used for holding the product tilted to improve reading of the label and facilitate picking up.

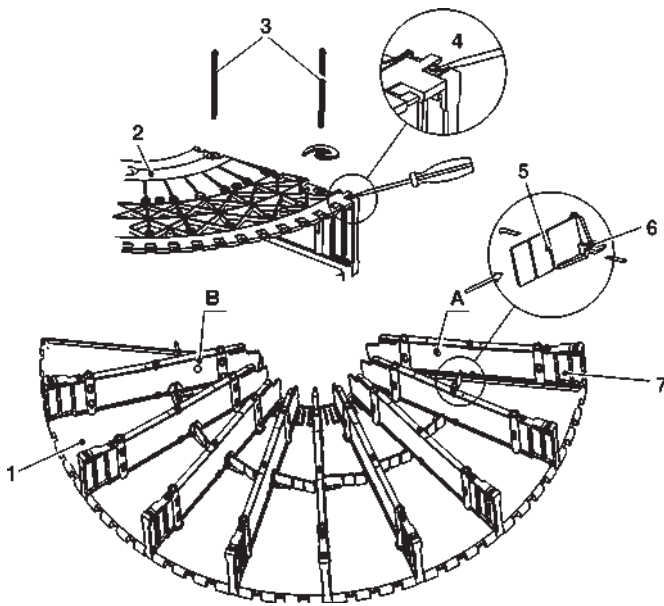

Fig. 16

- 1 - Lower half-disk
- 2 - Upper half-disk
- 3 - Rods
- 4 - Half-disk fastening catches
- 5 - Snapping cuts
- 6 - Support fastening hook
- 7 - Divider

To fit the supports do as follows:

- remove the relevant drum from the stack, separating the two drum-halves;
- completely slide out the rods and lift the upper half-disk, levering the catches up;
- check the width of the support according to the selected compartment and to its depth; if necessary, break the support to the desired size, pushing along the cuts;
- place the support at the bottom of the half-disk and push it toward the divider, until clicking the fastening hook;
- adjust the position, sliding the support on the divider;
- repeat the operation for the other dividers.

The product support is not installed on the outmost divider. The last divider (A), is fitted with two staggered supports (B). Reassemble all parts in the reverse order.

DISASSEMBLING THE DRUM STACK

The entire drum stack can be easily removed, but because of the dimension of the stack two persons are necessary to carry out this operation.

- Remove the upper drum.
- Undo the 2 hexagon head screws of the drum shaft support.
- Remove the external shaft support.
- Lift the stack assembly and pull it outwards from below.
- Re-assembly will be done in the reverse order.

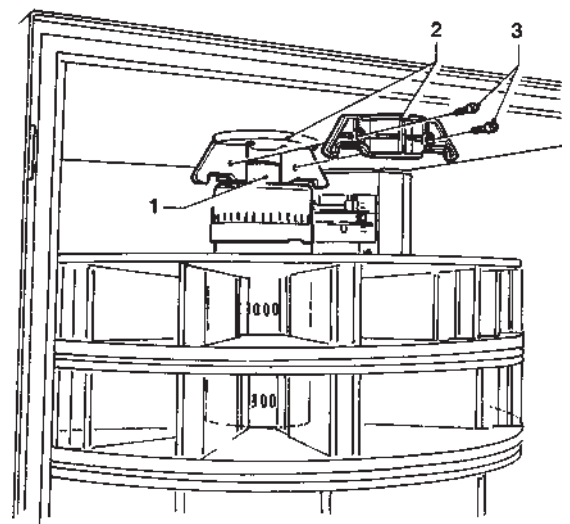

Fig. 17

- 1 - Shaft
- 2 - Shaft supports
- 3 - Hexagon head screws

COOLING SYSTEM

The cooling unit is mounted onto the base.
The cooling temperature, between 0° C and 3° C, is preset by the manufacturer.

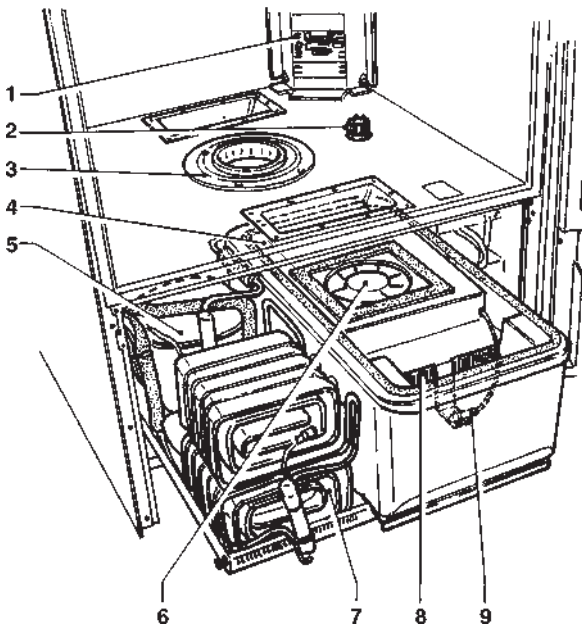

Fig. 18

- | | |
|------------------------|-------------------------|
| 1 - Stack of magnets | 5 - Compressor |
| 2 - Drive cog wheel | 6 - Central ventilation |
| 3 - Drum sliding guide | 7 - Condenser |
| 4 - Rear evaporator | 8 - Front evaporator |
| | 9 - Temperature sensor |

AUTOMATIC DEFROSTING DEVICE

Automatic defrosting is enabled through programming.
The defrosting system operation, indicated in Fig. 19, is as follows:

The bypass solenoid valve stays open until the sensor on the evaporator detects a temperature of 4° C.
However, the software ensures that the defrosting cycle does not exceed 10 minutes.

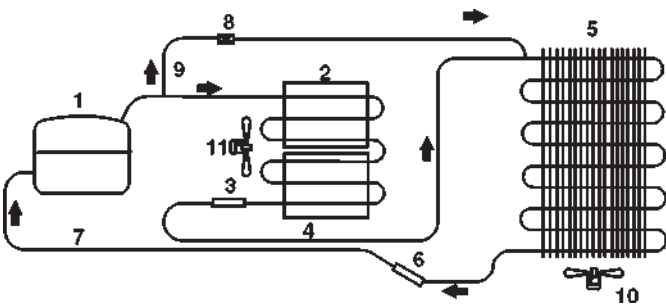

Fig. 19

- | | |
|--------------------------|----------------------|
| 1 - Compressor | 6 - Liquids trap |
| 2 - Condenser | 7 - Suction pipe |
| 3 - Dehumidifying filter | 8 - Bypass valve |
| 4 - Capillary pipe | 9 - Hot gas pipe |
| 5 - Evaporator | 10 - Evaporator fans |
| | 11 - Condenser fan |

The hot gas produced by the compressor flows directly to the evaporator through the bypass pipe.
With the bypass solenoid valve open the evaporator fans are stopped, to avoid a temperature increase inside the refrigerated box.

MAINTENANCE AND CLEANING

The machine must be kept clean at all times, both inside and outside.

Normally available products, as long as they are mild, may be used for cleaning.

When cleaning the drum halves in a dish washer, the water temperature should never exceed 60° C.

Any detergent residue can cause unpleasant odour inside the machine!

To ensure perfect operation, the product slider guides should always be kept clean.

Never use grease or oil!

IMPORTANT NOTICE

The drums must never come into contact with grease or oil!

The condenser must be kept clean using a vacuum cleaner, a brush etc.

POWER SUPPLY UNIT

The fuses, switches and connectors which are on the front of the power supply unit have the functions indicated below.

When the protective casing is fitted, only the fuses and the main switch are accessible.

When replacing any fuses the machine must be disconnected from the power supply.

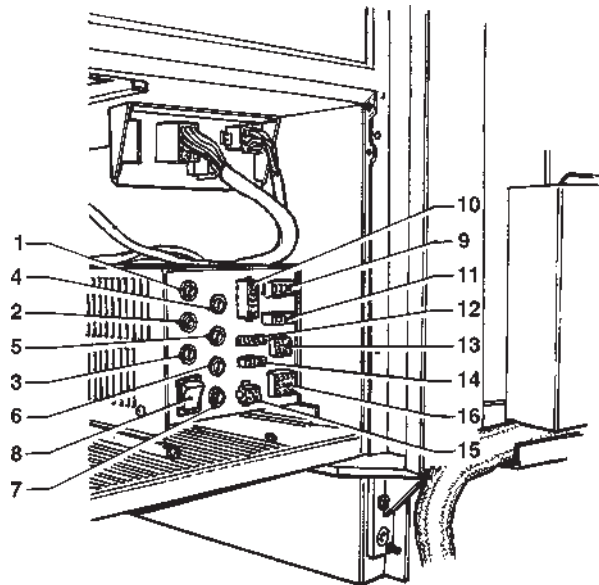
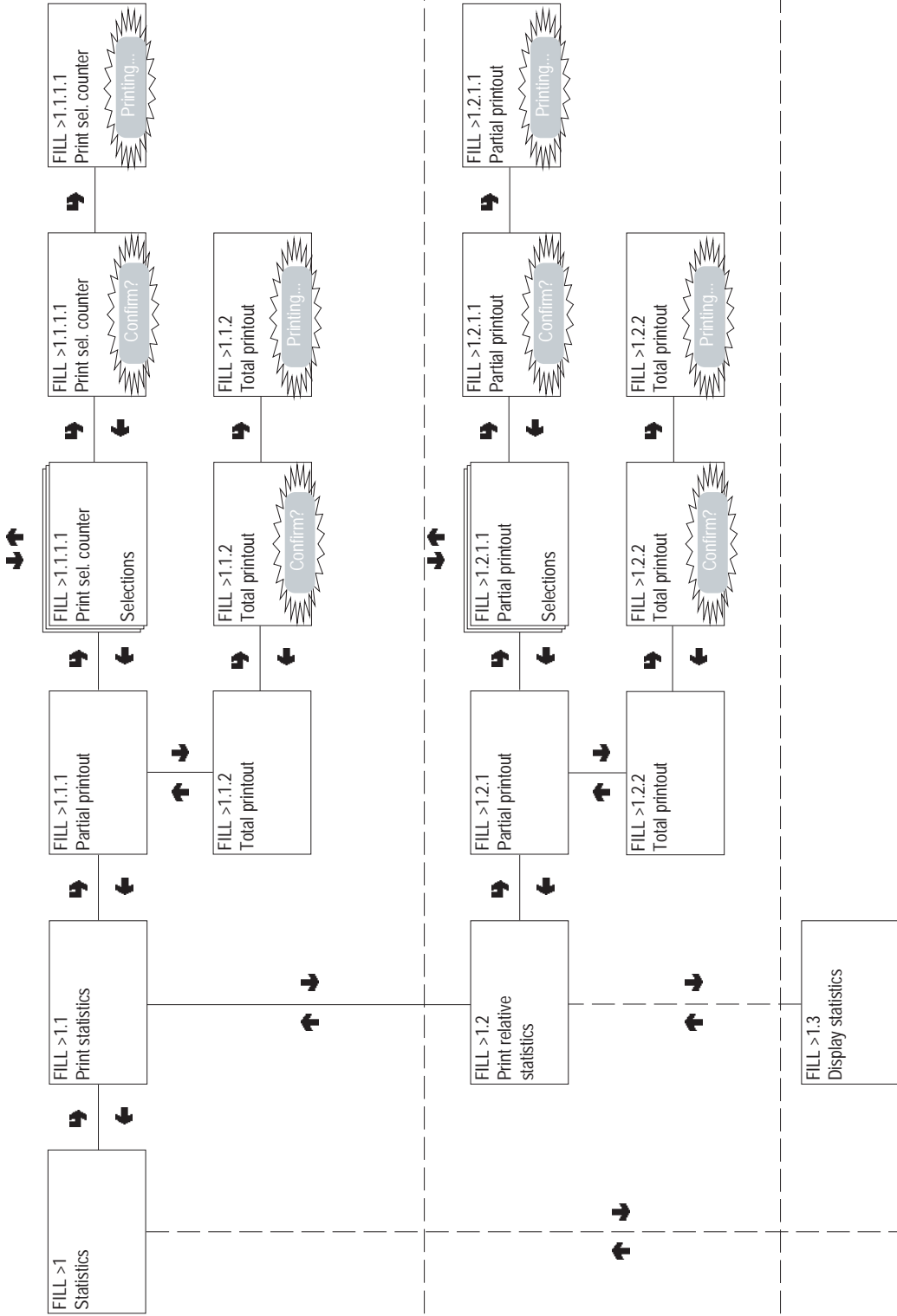

Fig. 20

- | | |
|----|---|
| 1 | Transformer primary winding fuse |
| 2 | Executive coin mechanism fuse |
| 3 | 24 V DC fuse |
| 4 | Heating element fuse |
| 5 | Drum magnet fuse |
| 6 | Line fuse |
| 7 | Line fuse |
| 8 | Main switch |
| 9 | Power supply to drum magnets and heating elements |
| 10 | Connection to stack motor |
| 11 | Connection to door lamp |
| 12 | Connection to cabinet lamp |
| 13 | Power supply to coin mechanism and CPU board |
| 14 | Connection to sensors |
| 15 | Connection to cold unit |
| 16 | Connection to control board |

Filler menu - Summary



TOTAL STATISTICS

With the printer connected print all data as displayed

Print data for:

- Selections
- Time bands
- Discount/overprice
- Failures
- Coin mechanism data

Heading:

- Current date
- Machine model
- Software edition
- Operator code
- Machine code
- Installation date

Print data for:

- Selections
- Time bands
- Discount/overprice
- Failures
- Coin mechanism data

RELATIVE STATISTICS

 Programming button

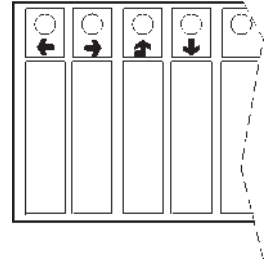

Filler menu - Summary

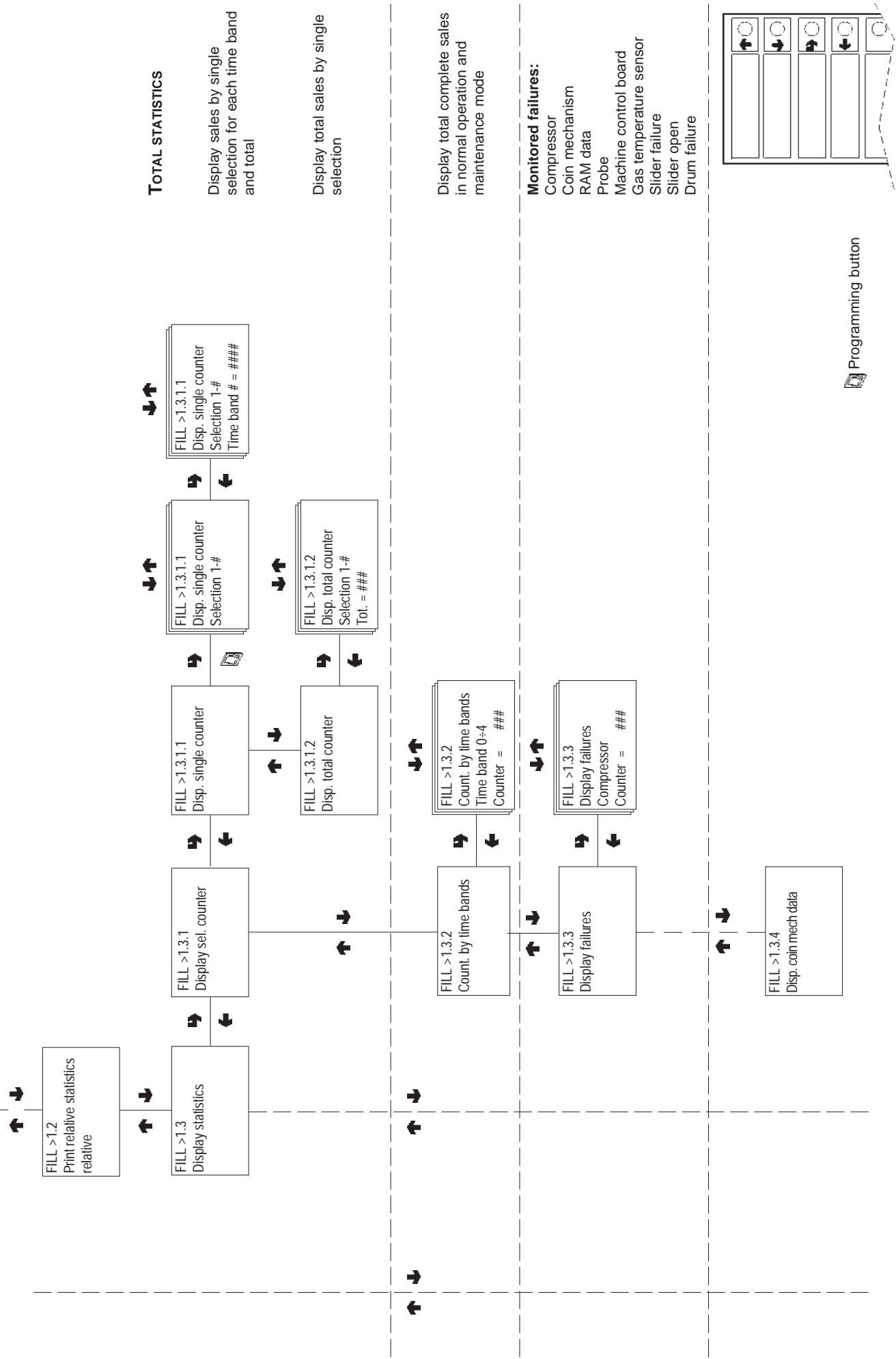

TOTAL STATISTICS

Display sales by single selection for each time band and total

Display total sales by single selection

Display total complete sales in normal operation and maintenance mode

Monitored failures:

- Compressor
- Coin mechanism
- RAM data
- Probe
- Machine control board
- Gas temperature sensor
- Slider failure
- Slider open
- Drum failure

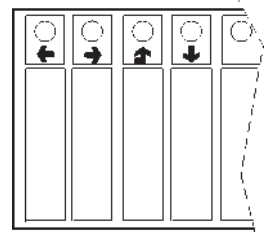

Programming button

Filler menu - Summary

COIN MECHANISM DATA
(according to protocol used)

Validators and Executive
Cashed and sold

BDV Audit

MDB Audit

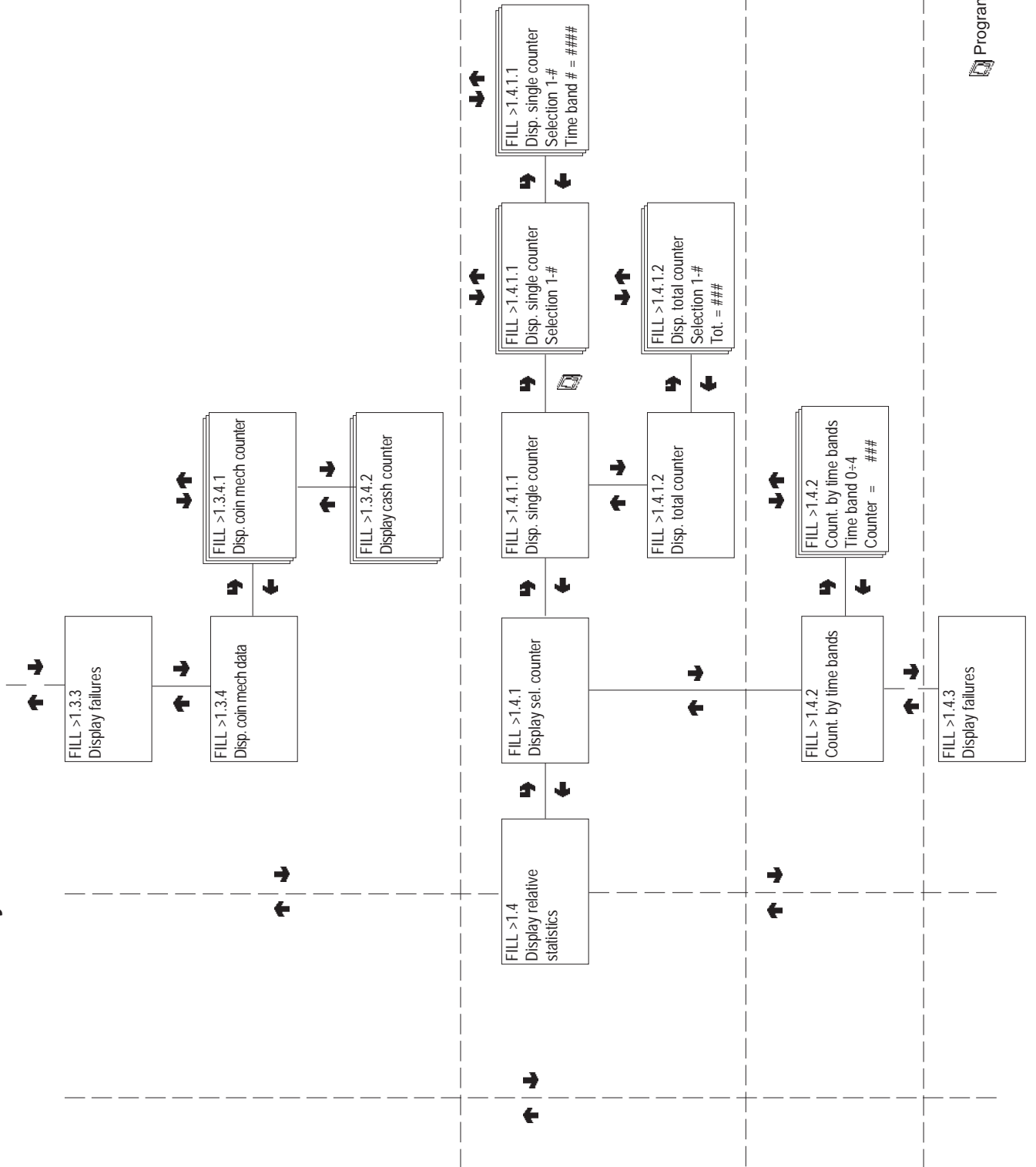

Programming button

Filler menu - Summary

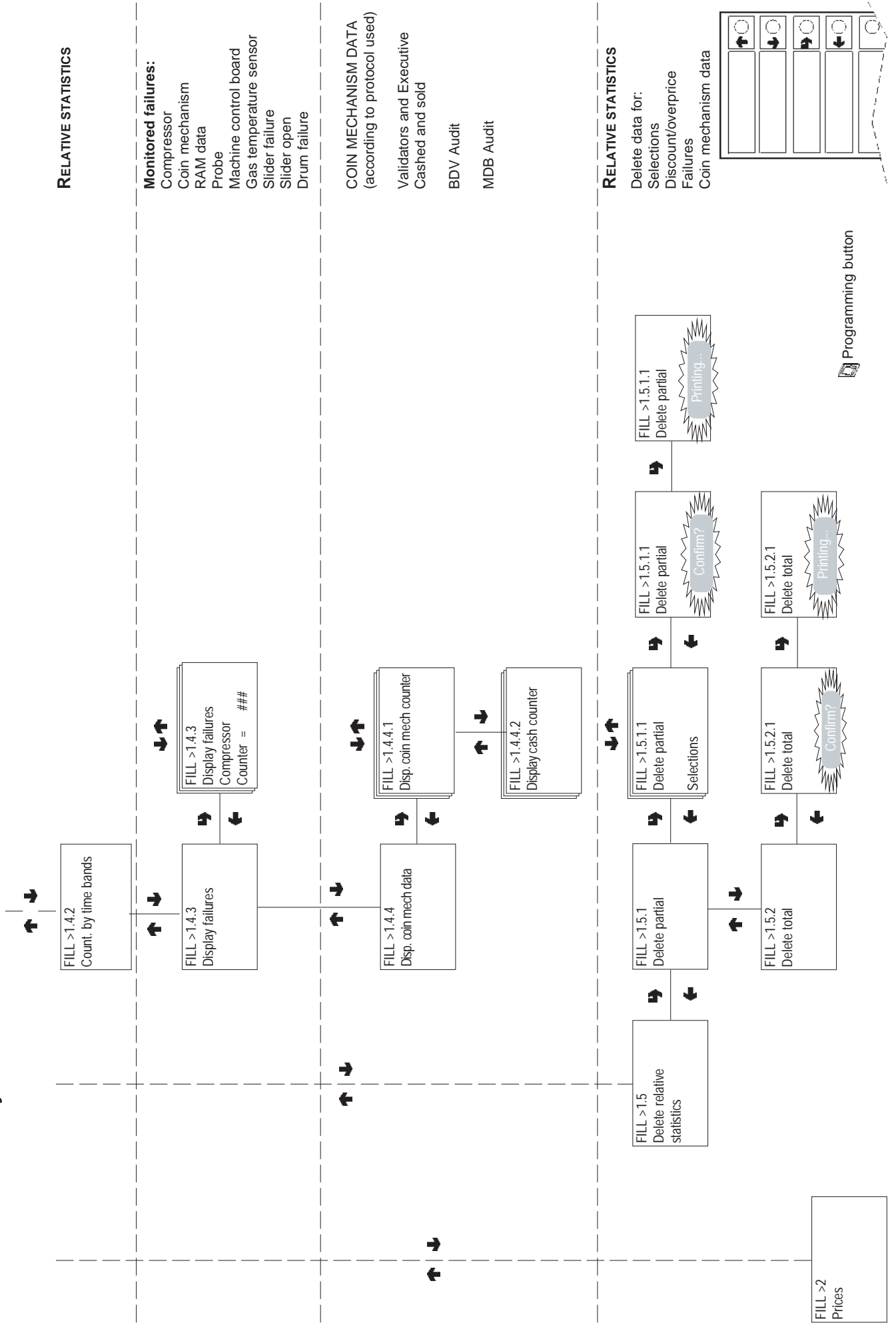

Filler menu - Summary

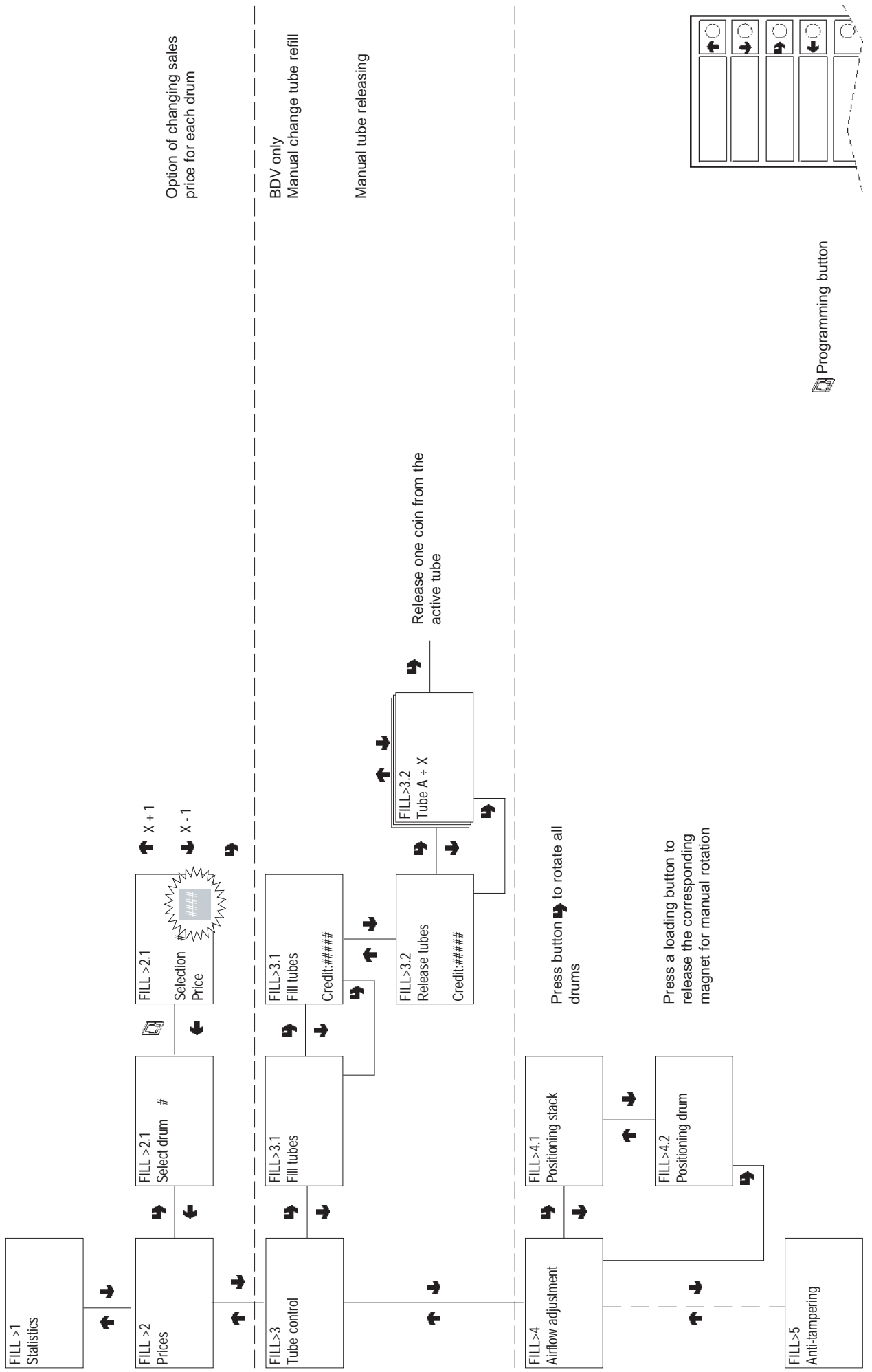

Option of changing sales price for each drum

BDV only
Manual change tube refill

Manual tube releasing

Press button to rotate all drums

Press a loading button to release the corresponding magnet for manual rotation

Programming button

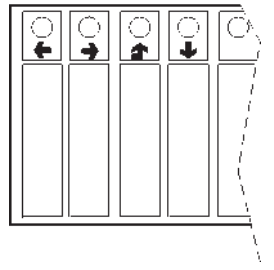

Filler menu - Summary

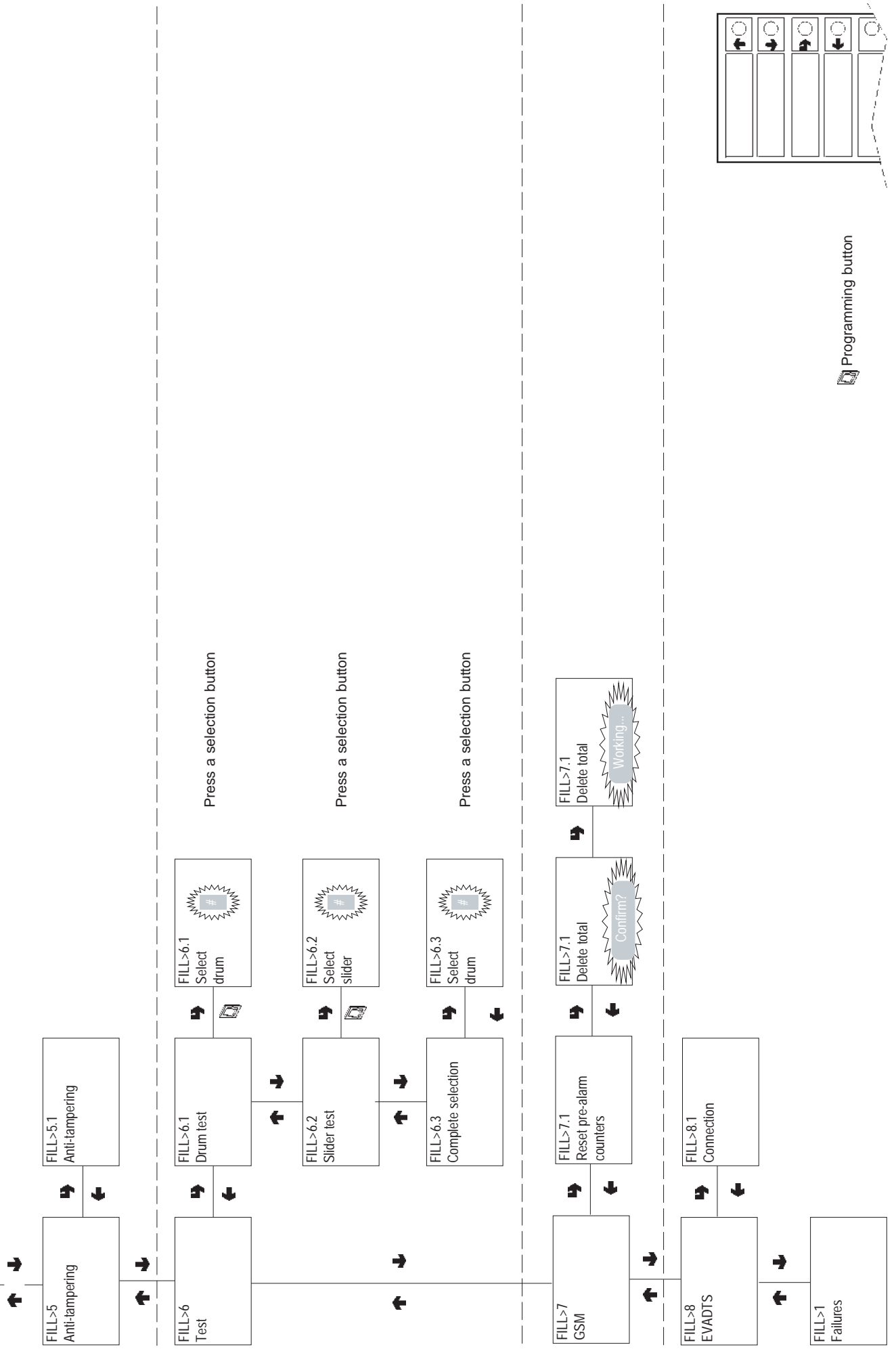

Technician menu - Summary

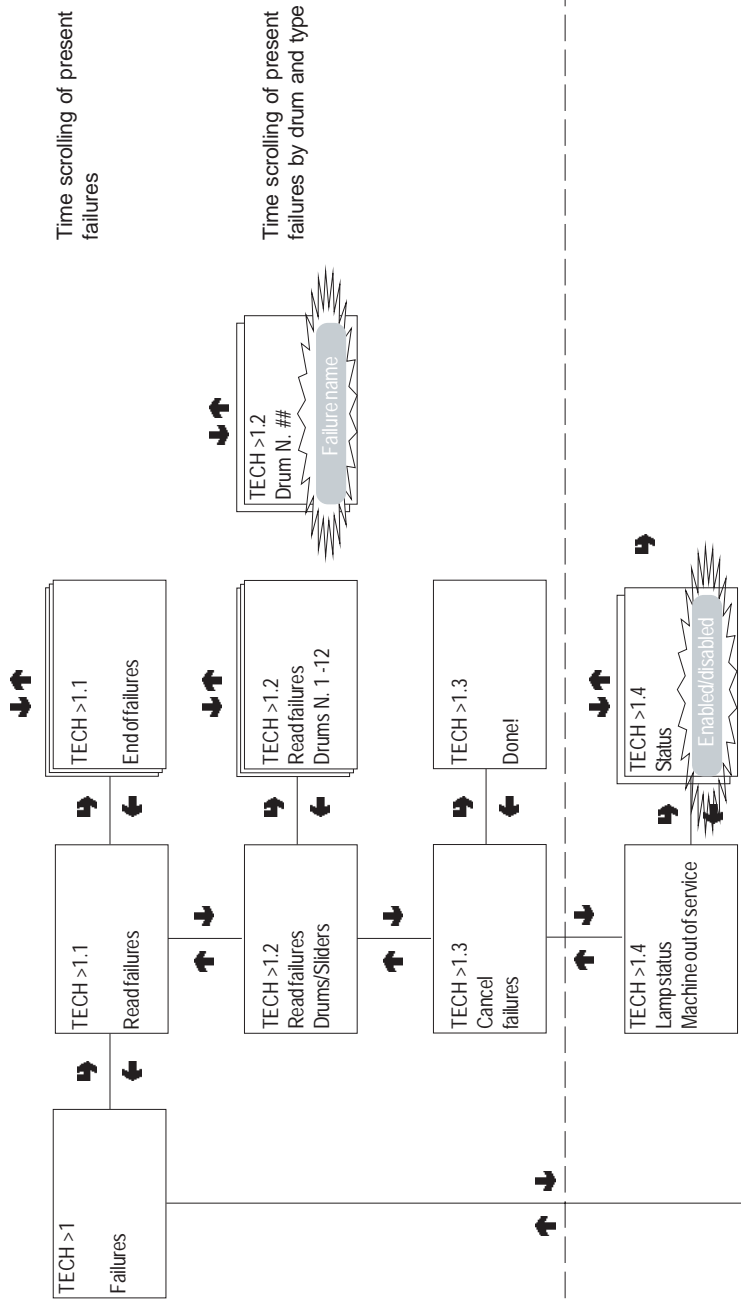

DISPLAYING FAILURES

Monitored failures:

- Compressor
- Coin mechanism
- RAM data
- Probe
- Machine control board
- Gas temperature sensor

- 1 to 12
- Slider failure
- Slider open
- Drum failure

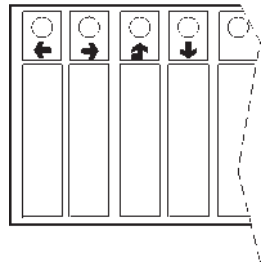

Programming button

Technician menu - Summary

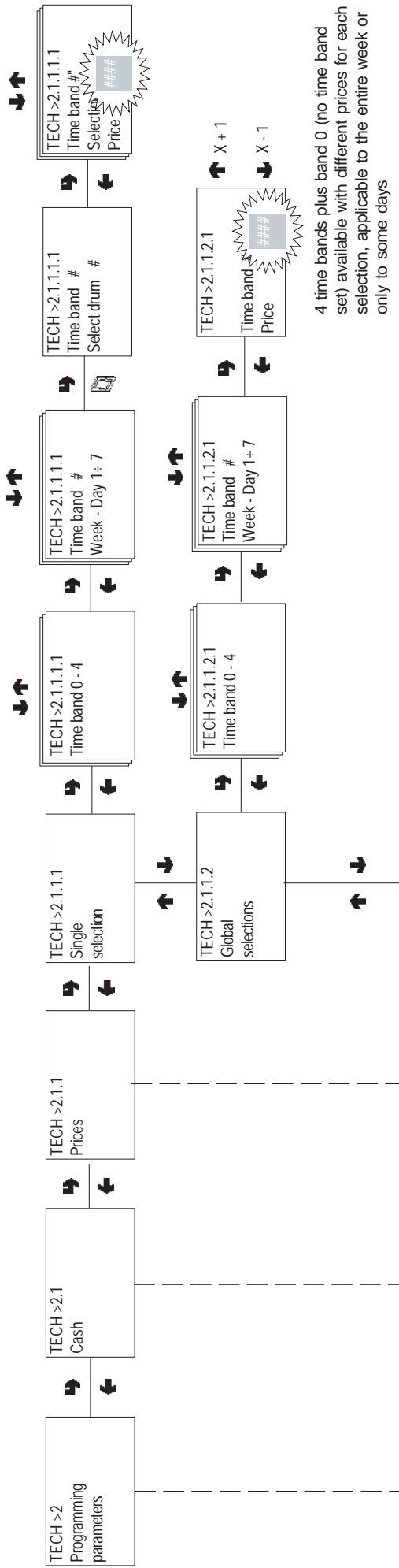

CLOCK

When confirming the blinking values, day, month, year and week day are entered one after the other. When confirming the week day hour and minutes are displayed, that can then be changed and confirmed.

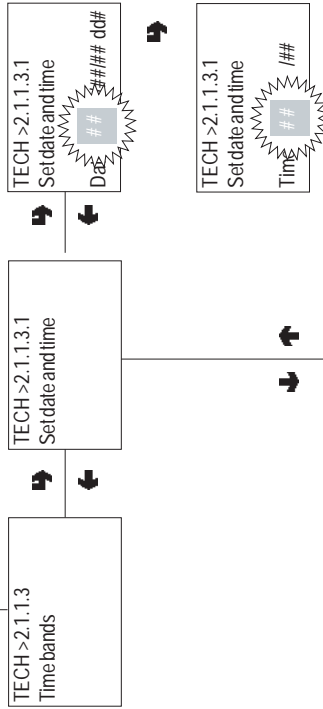

TIME BANDS

When confirming the blinking values, hour and minute for start and end of time band are entered one after the other. When start and end of time band are set to 24.00 the bands are not activated.

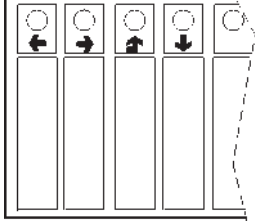
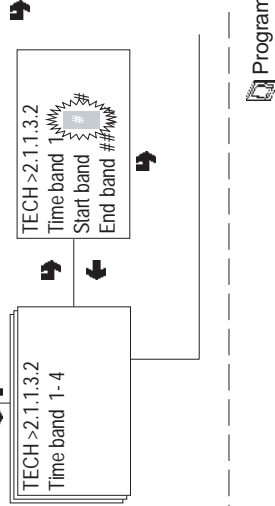

Technician menu - Summary

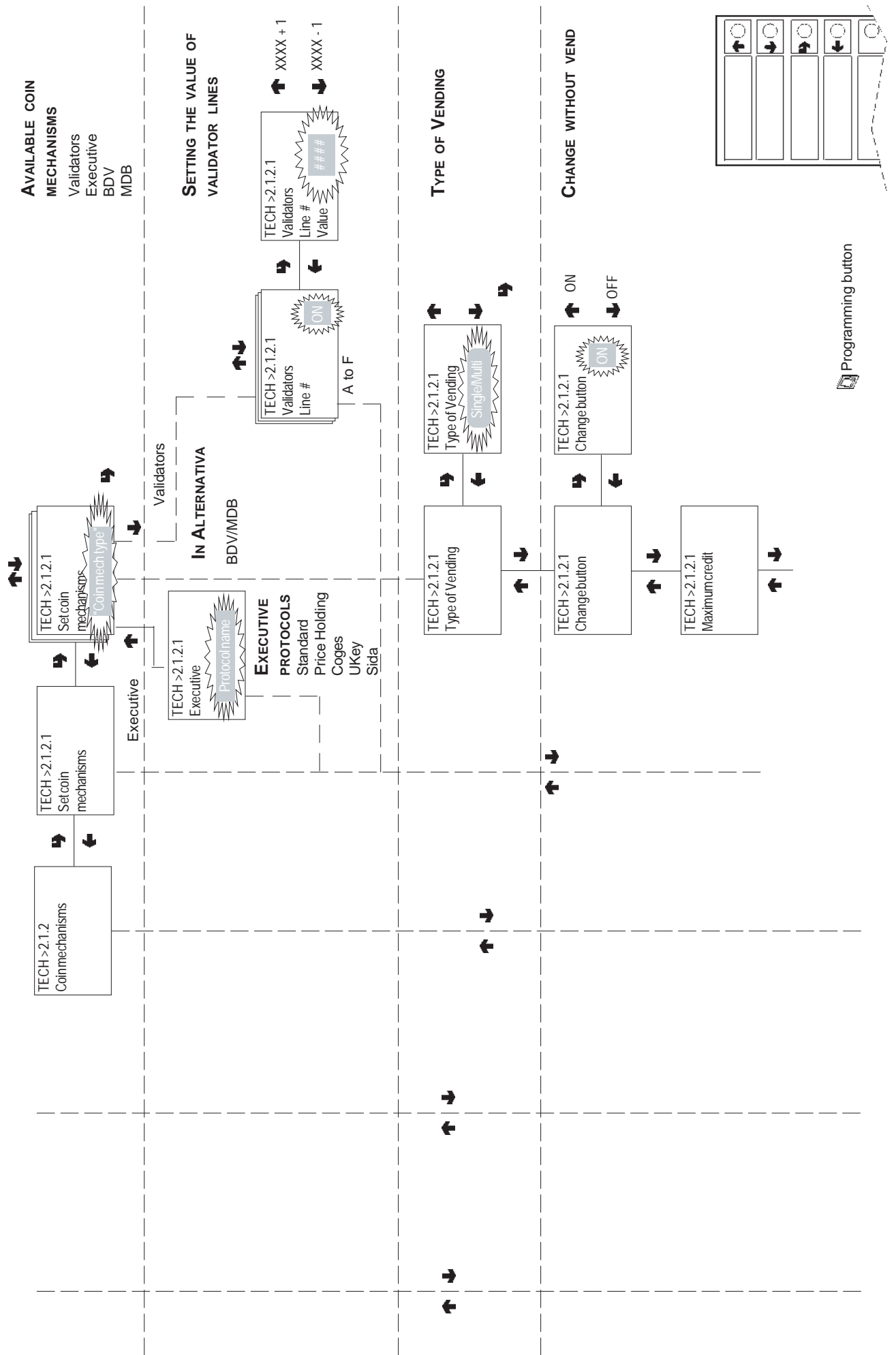

Technician menu - Summary

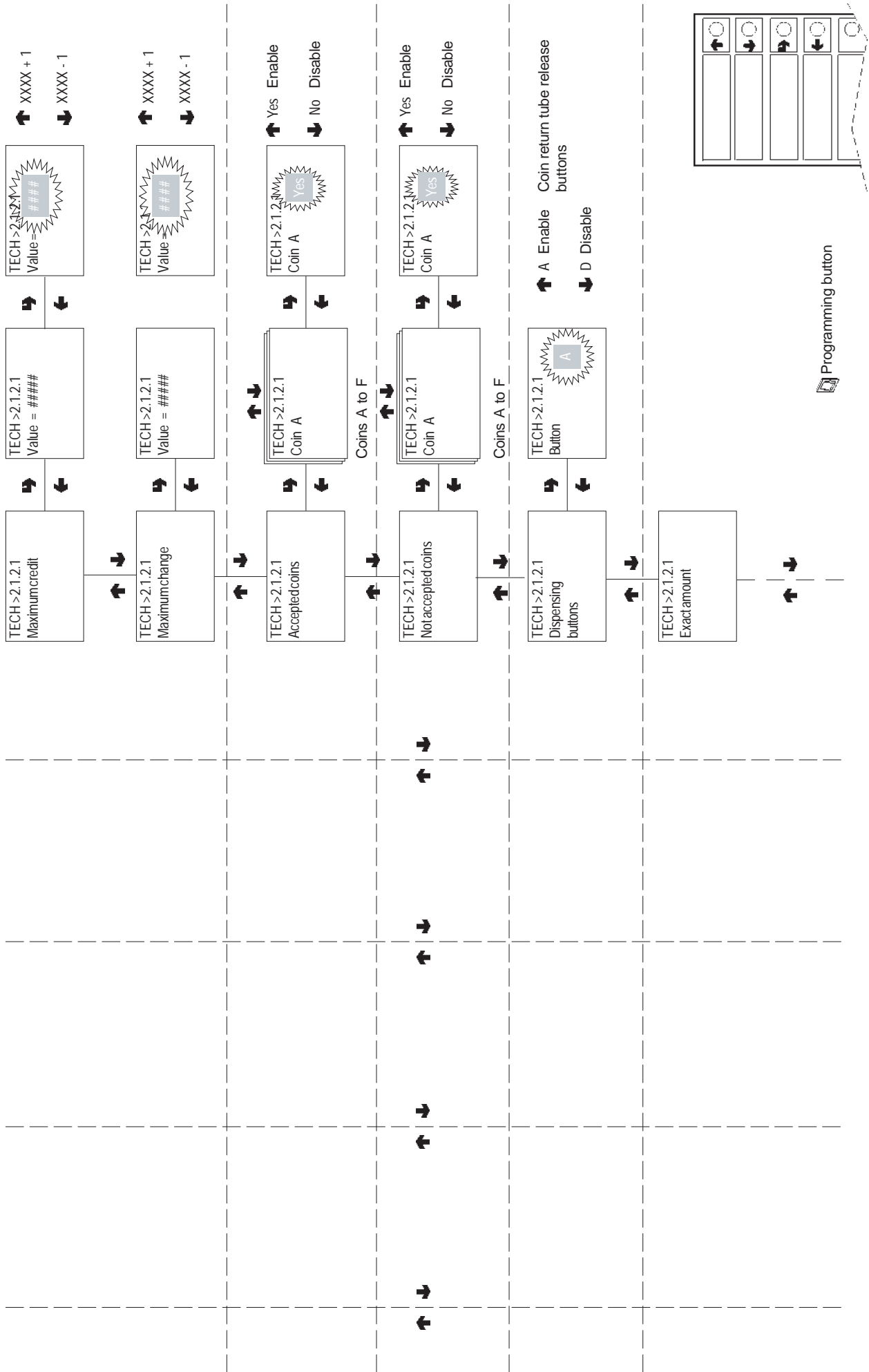

Technician menu - Summary

- 0 = A or (B and C)
- 1 = A and B and C
- 2 = A and B only
- 3 = A and (B or C)
- 4 = A only
- 5 = A or B only (default)
- 6 = A or B or C
- 7 = A or B only
- 8 = A or C only
- 9 = B and C only
- 10 = B only
- 11 = B or C only
- 12 = C only

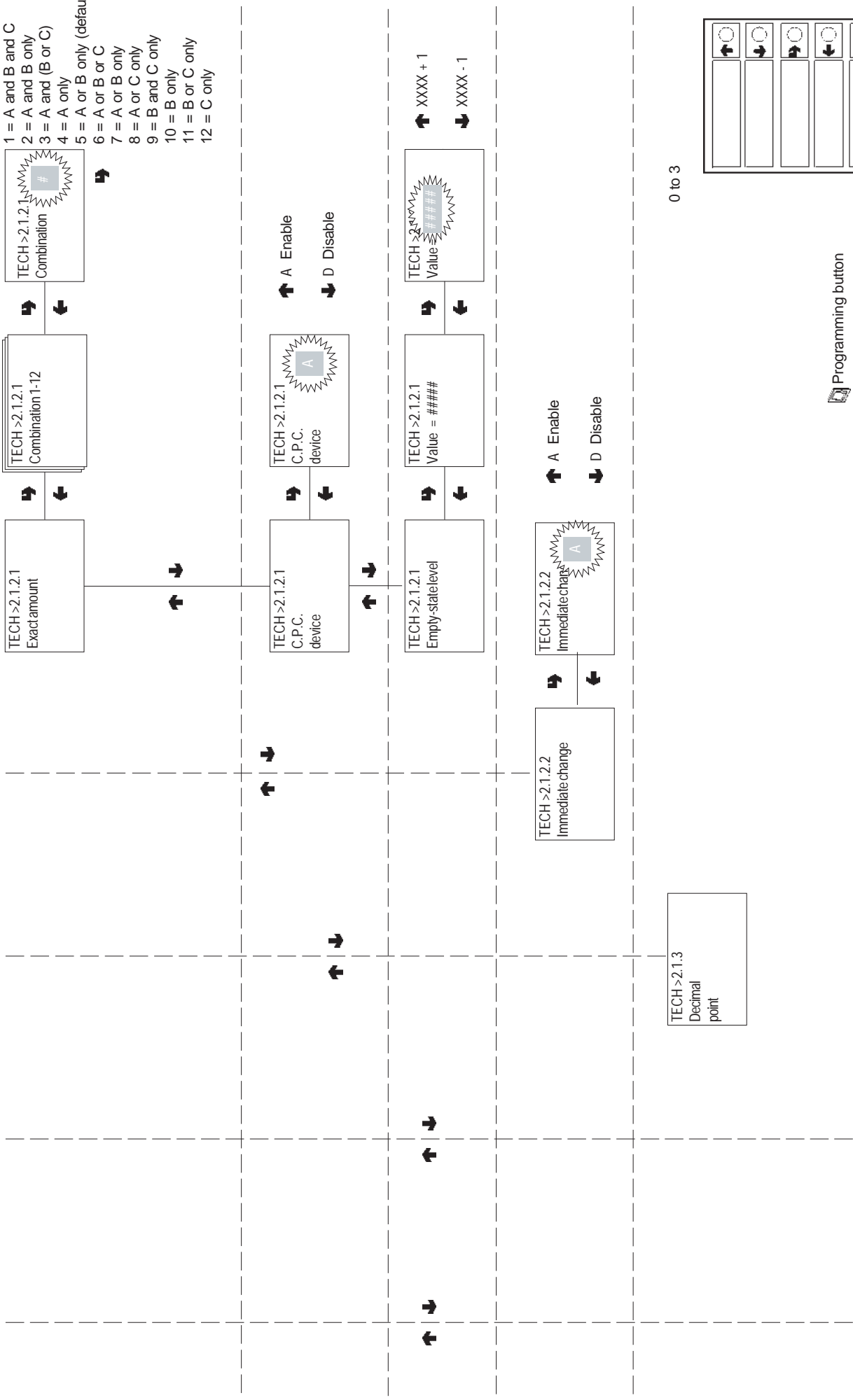

0 to 3

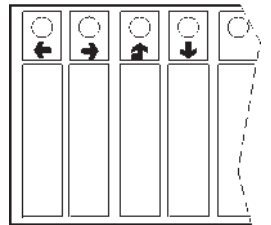

Technician menu - Summary

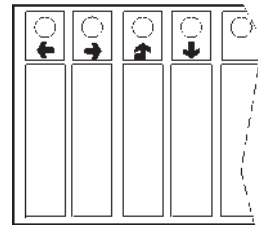
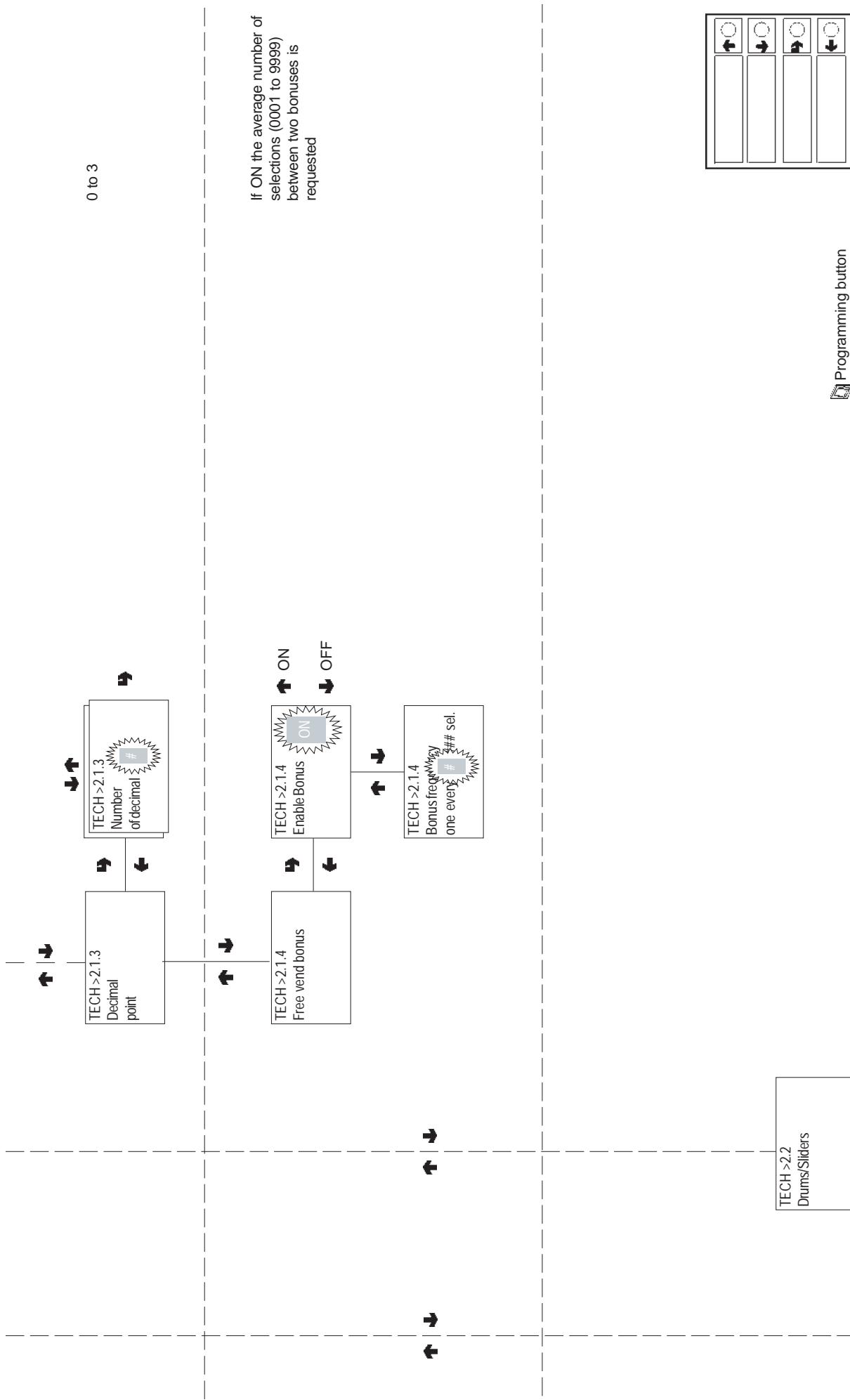

Programming button

Technician menu - Summary

4-digit number identifying the drum

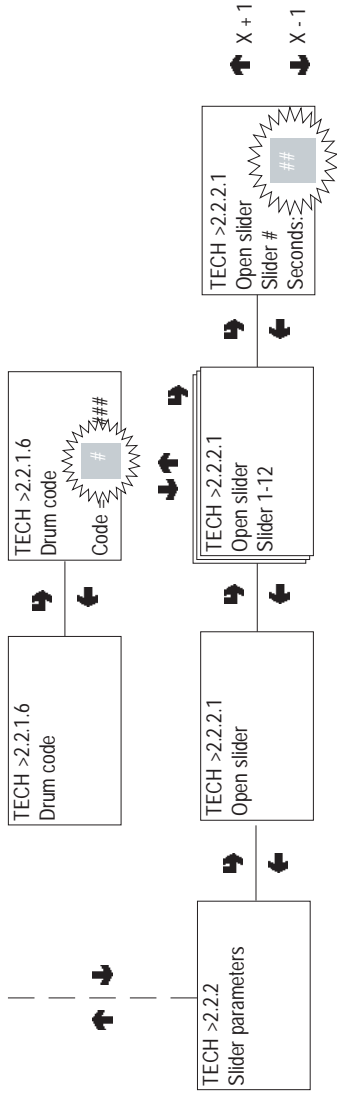

Operating temperature 3°C to 15°C. 3°C by default

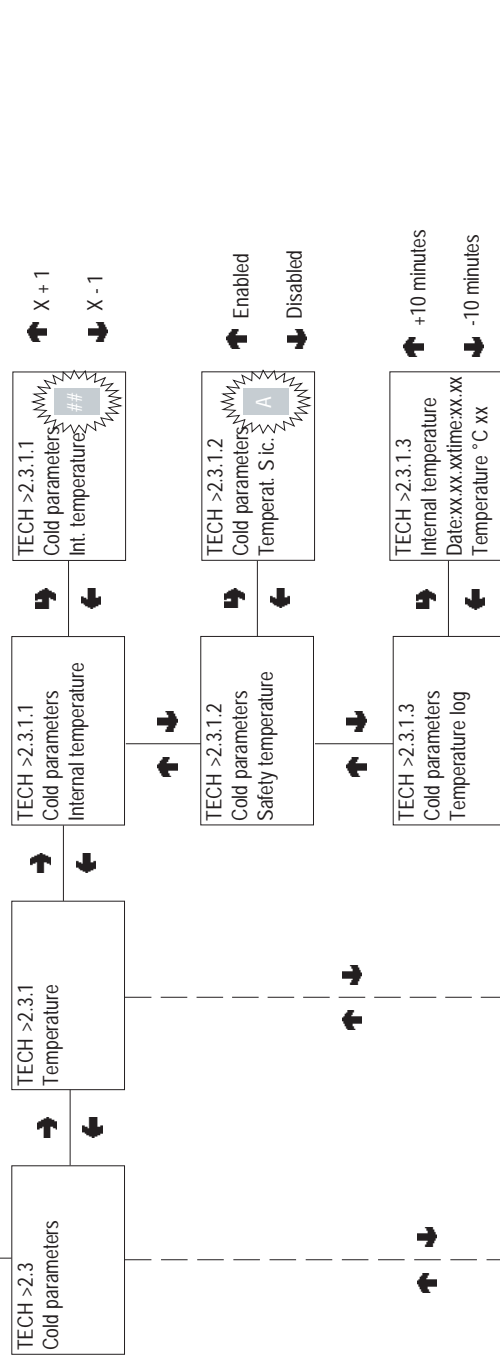

Programming button

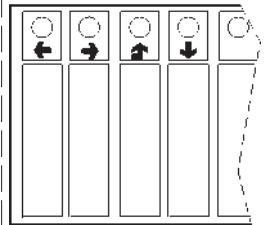

Technician menu - Summary

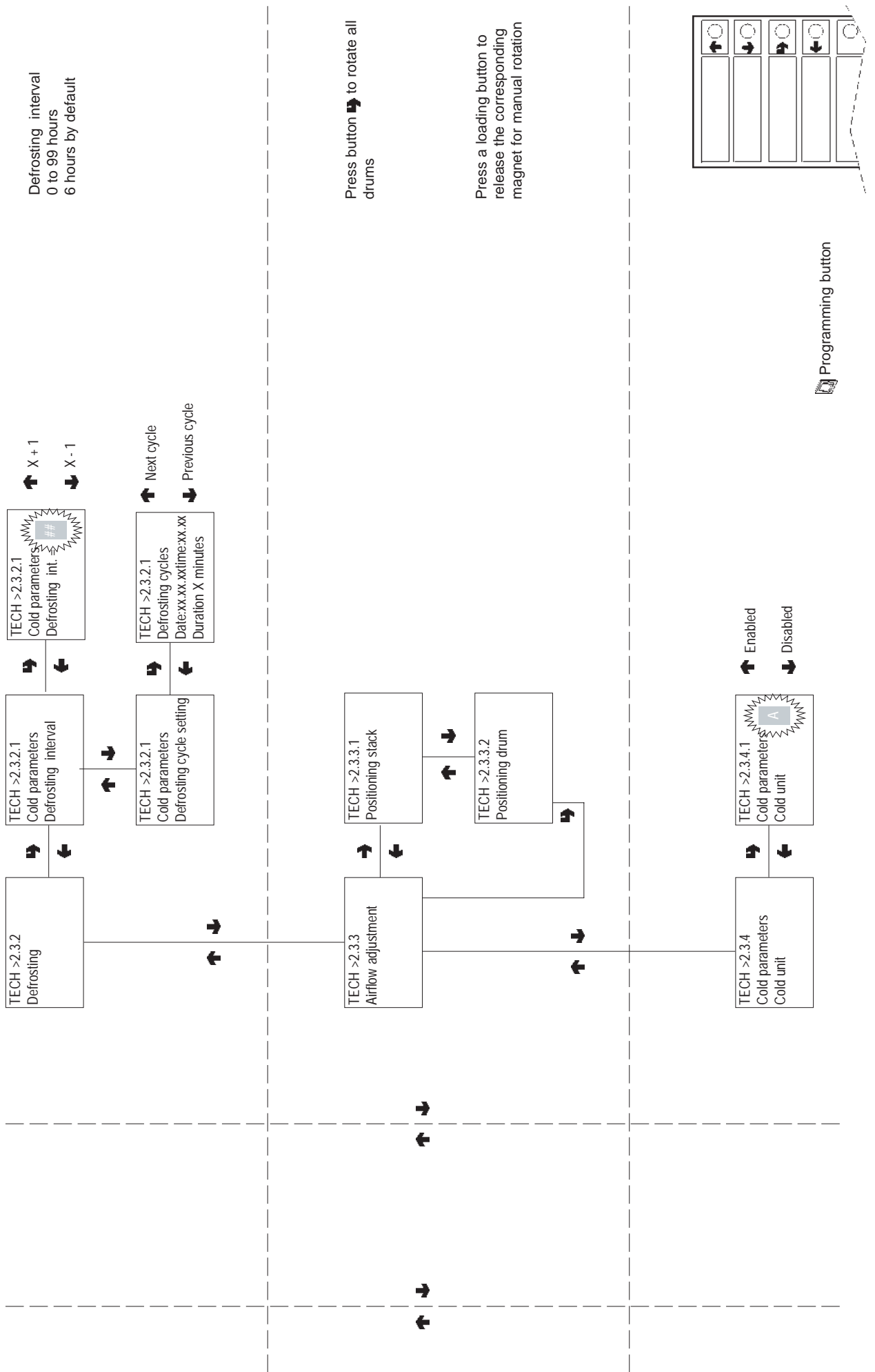

Technician menu - Summary

AVAILABLE LANGUAGES

- Italian
- German
- English
- French
- Spanish
- Portuguese
- Flemish

POSSIBLE MESSAGES

- No message
- Internal temperature
- Date and time

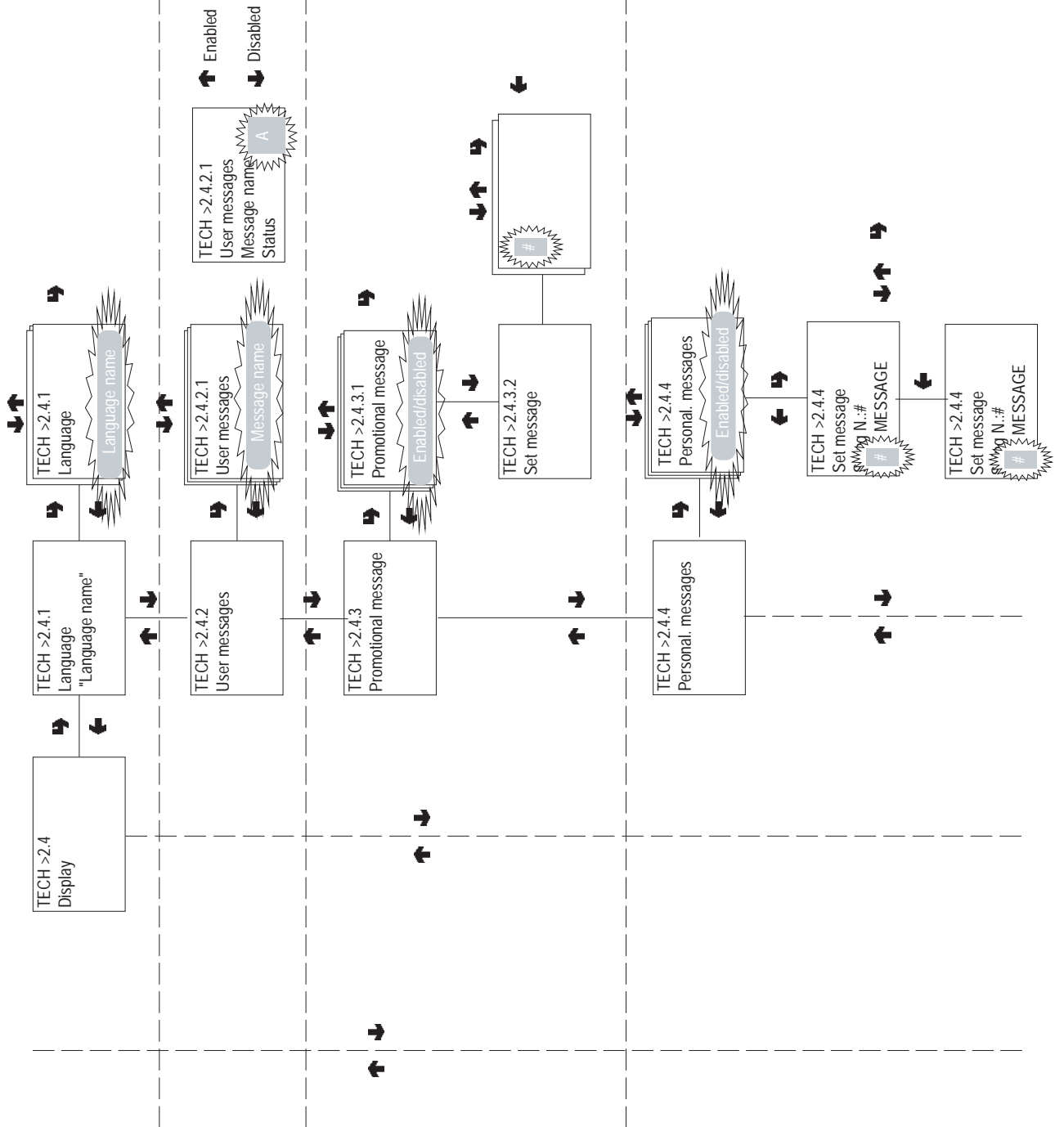

CHANGE USER MESSAGE

- Letter scrolling (up/down arrows)
- Next letter (right arrow)
- Next message (left arrow)

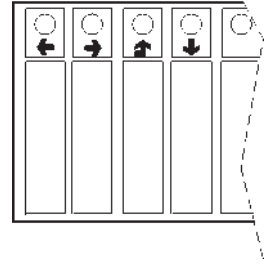

Programming button

Technician menu - Summary

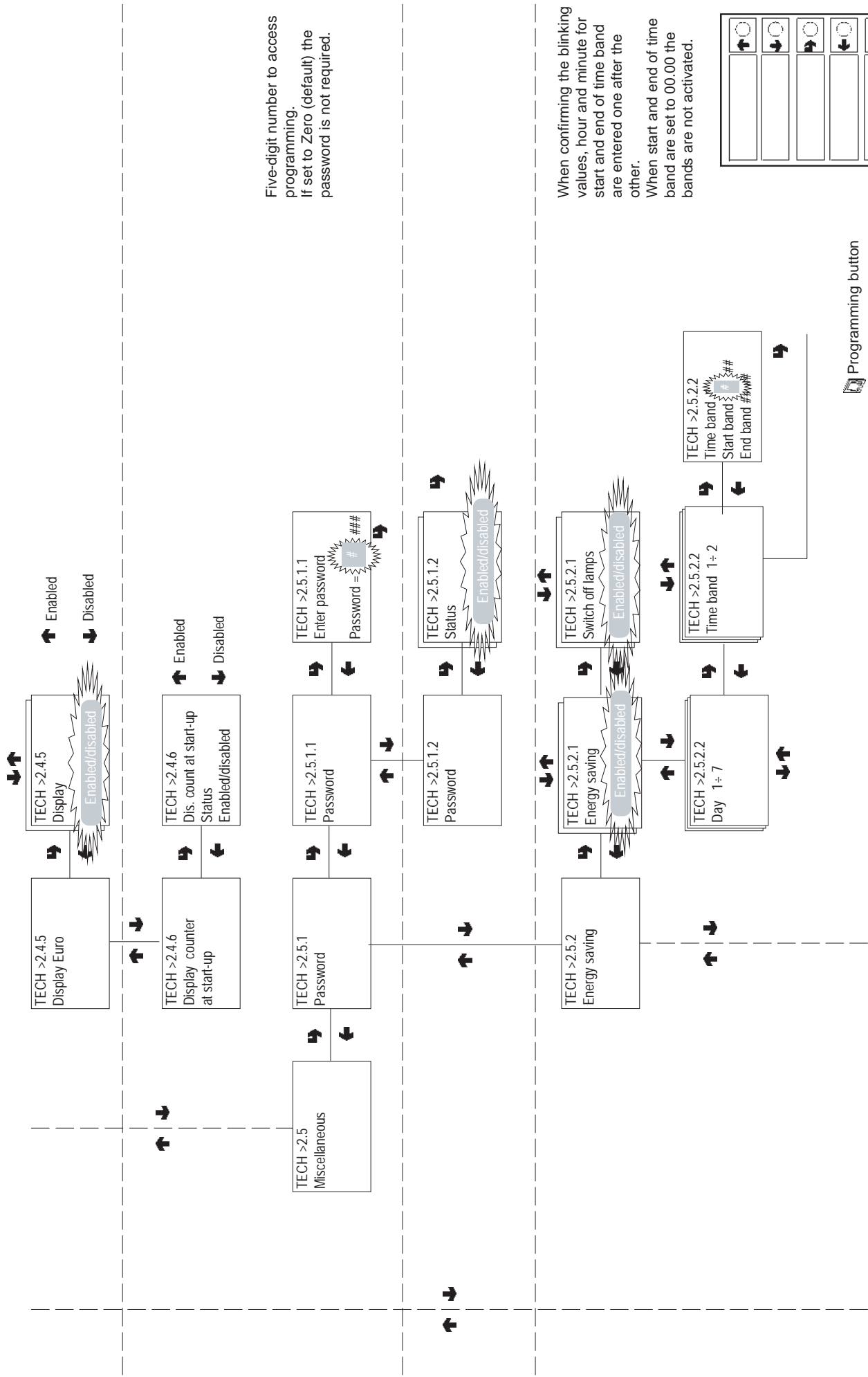

Five-digit number to access programming.
If set to Zero (default) the password is not required.

When confirming the blinking values, hour and minute for start and end of time band are entered one after the other.
When start and end of time band are set to 00.00 the bands are not activated.

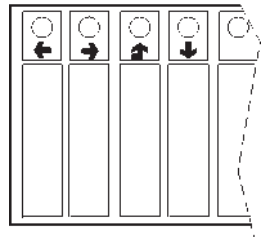

Programming button

Technician menu - Summary

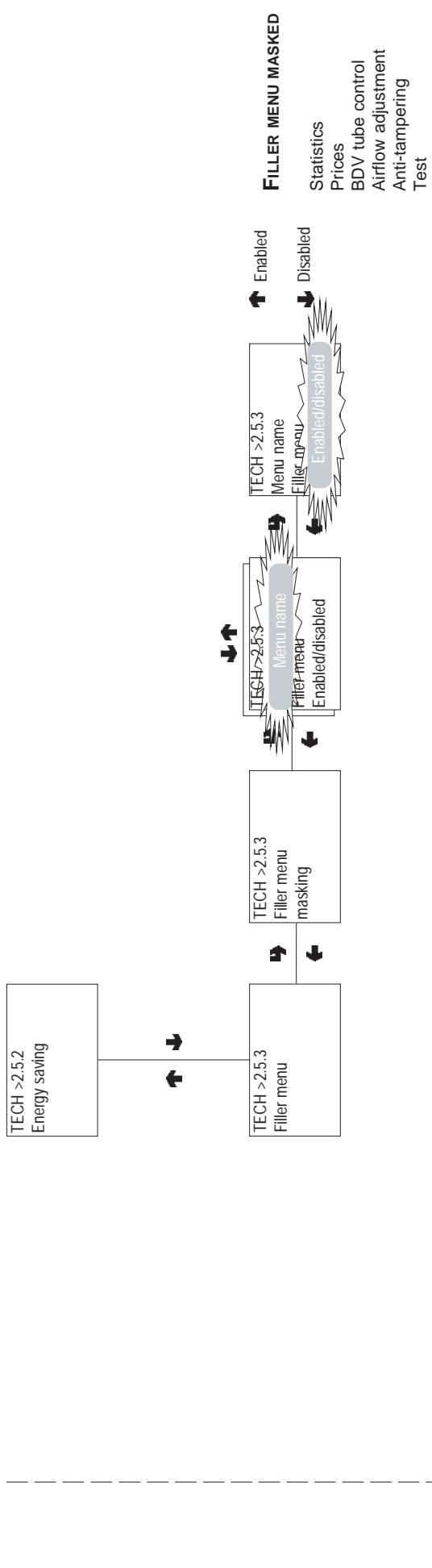

TECH >3
Statistics

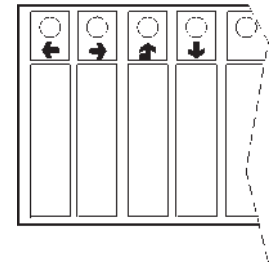

 Programming button

Technician menu - Summary

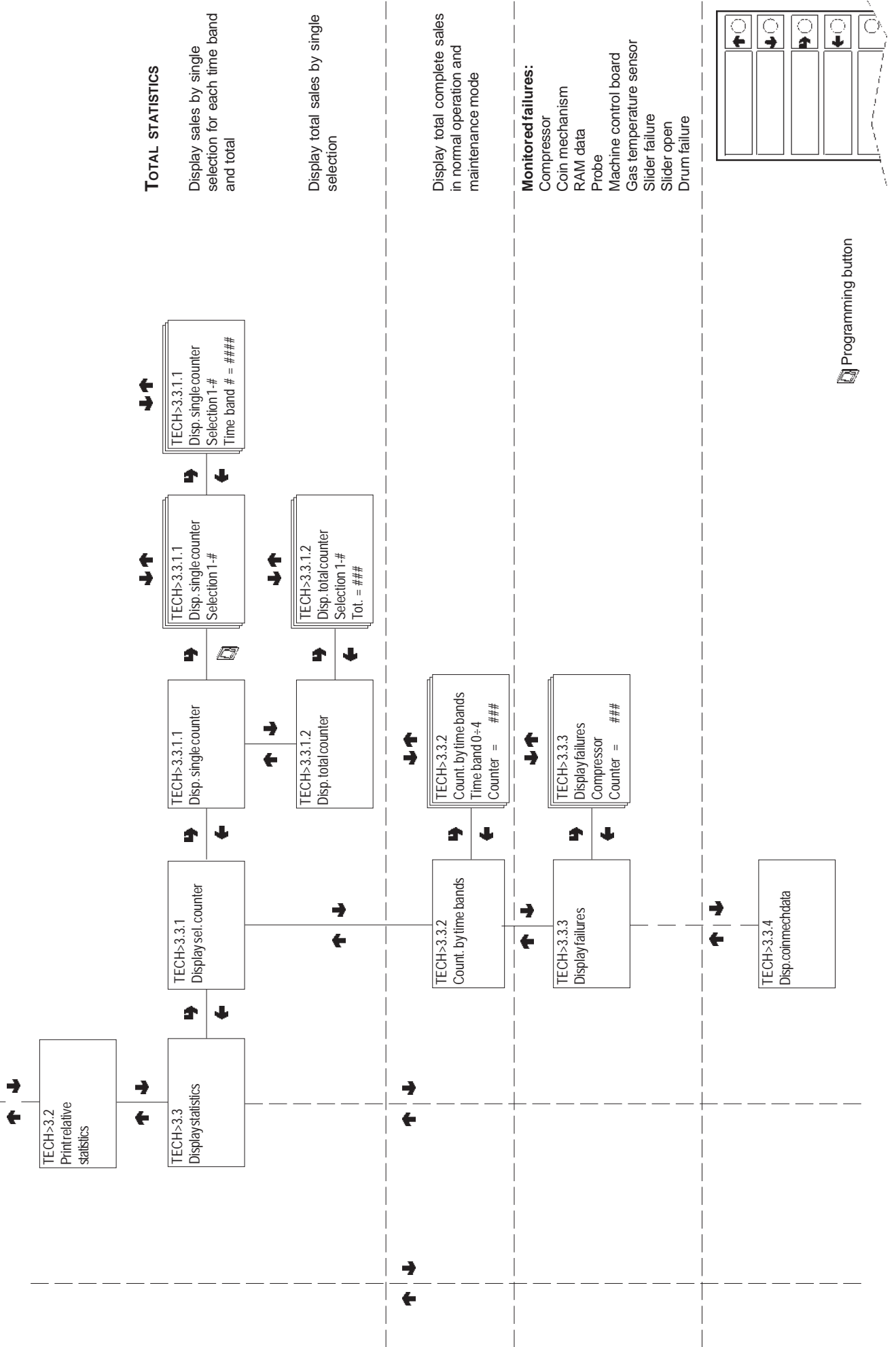

Technician menu - Summary

COIN MECHANISM DATA
(according to protocol used)

Validators and Executive
Cashed and sold

BDV Audit

MDB Audit

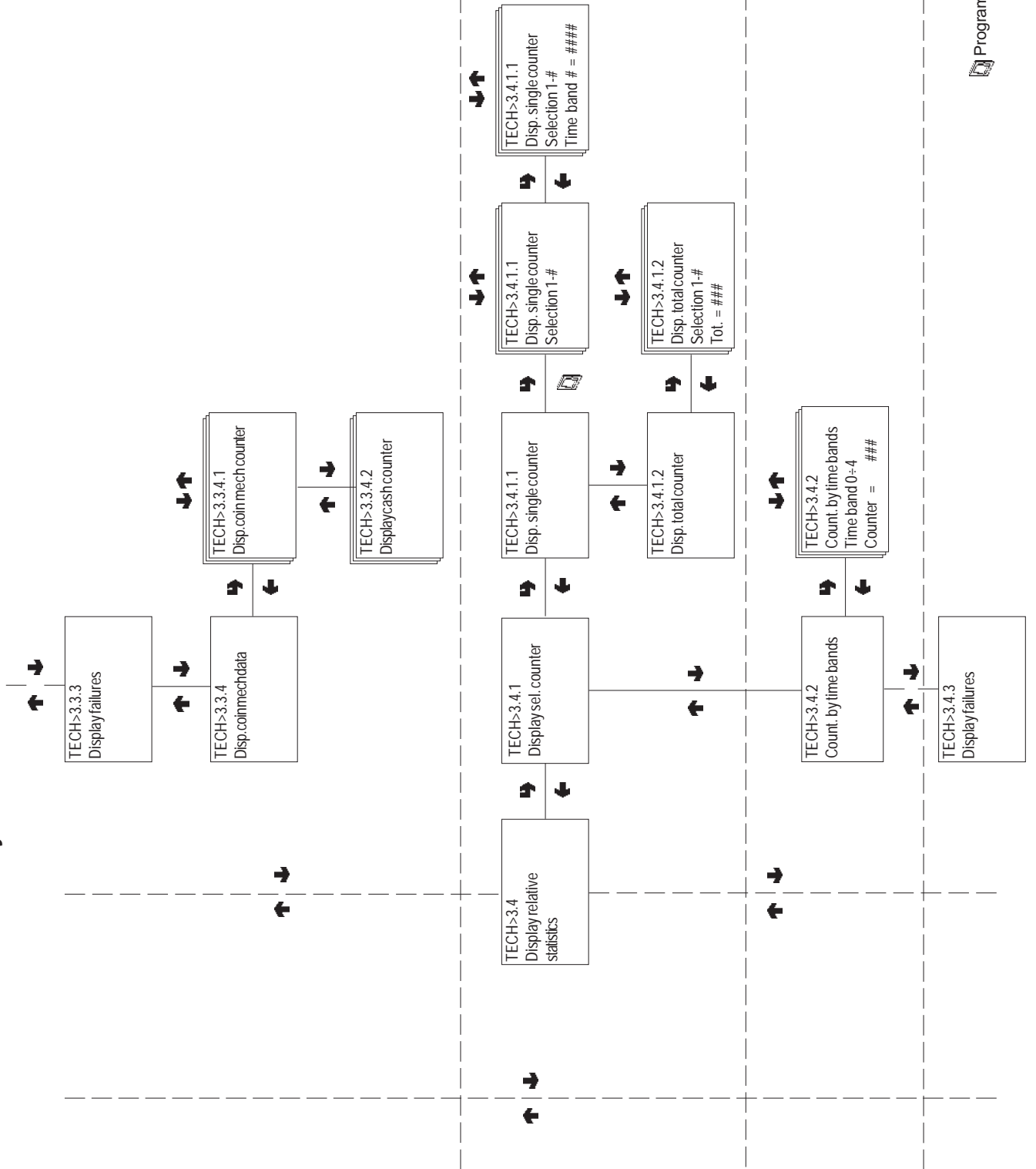

Technician menu - Summary

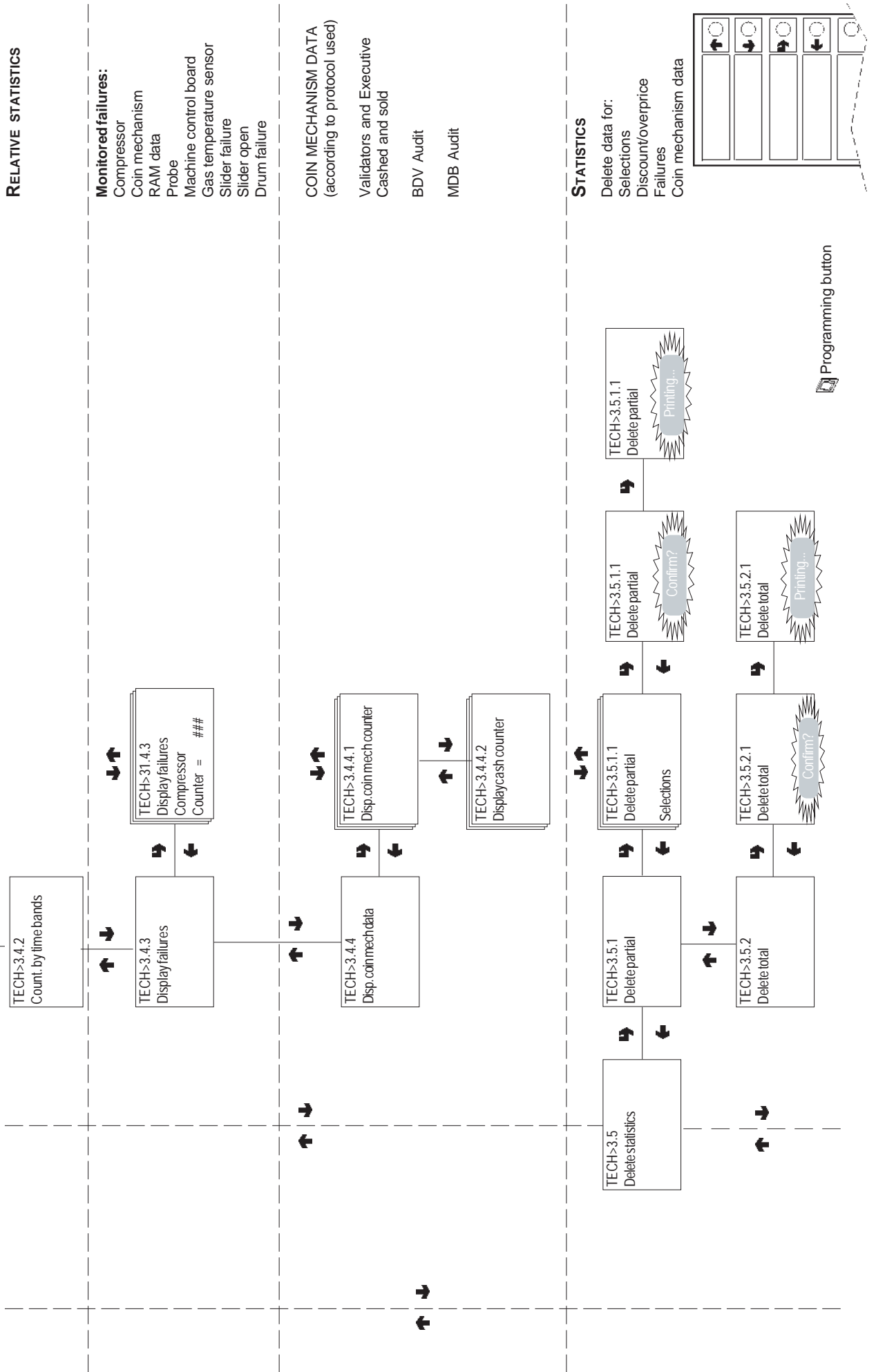

Technician menu - Summary

RELATIVE STATISTICS

- Delete data for:
- Selections
- Discount/overprice
- Failures
- Coin mechanism data

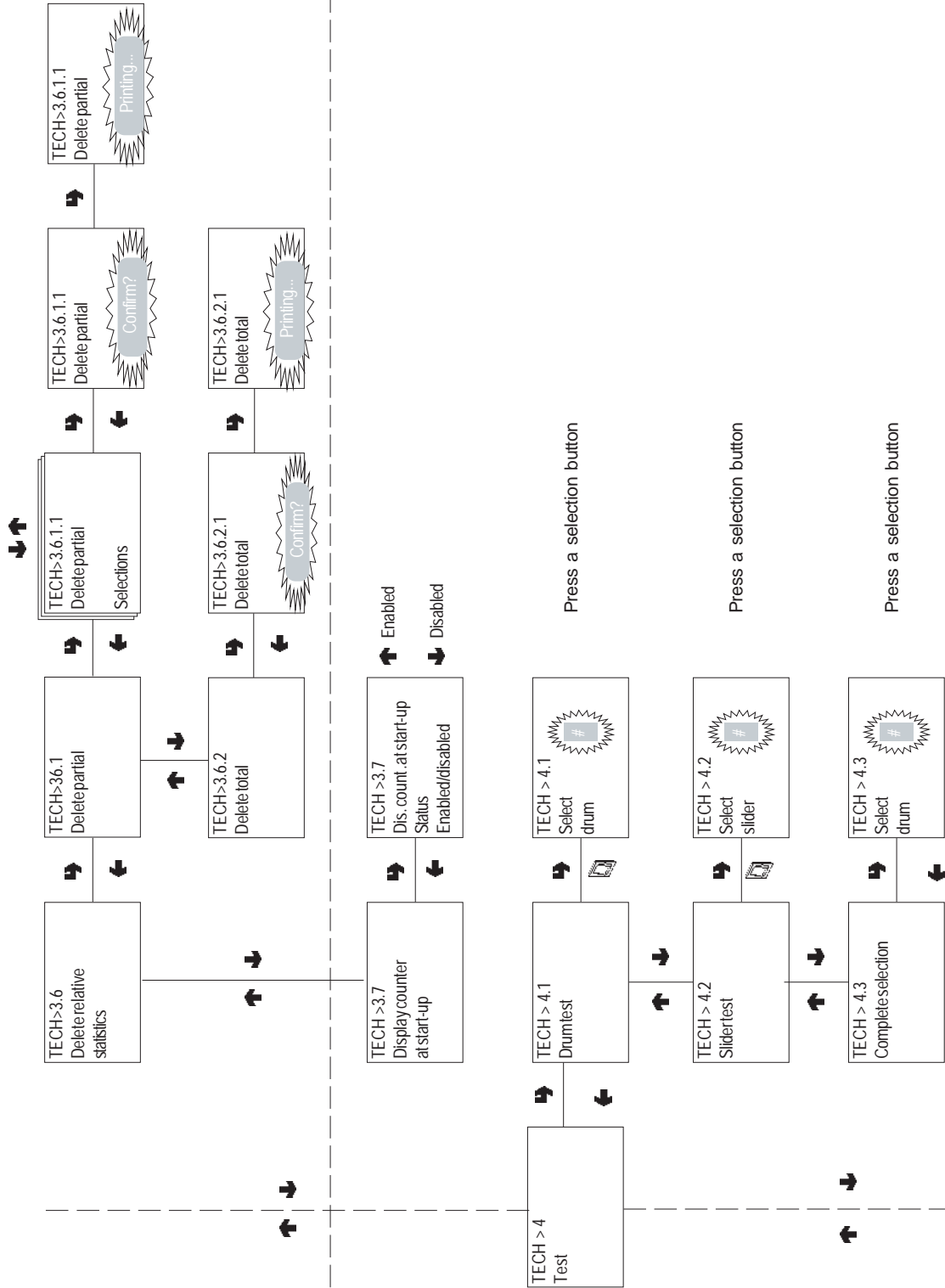

Programming button

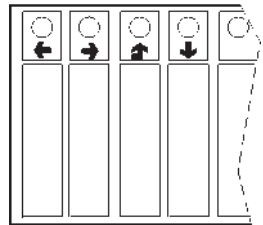

Technician menu - Summary

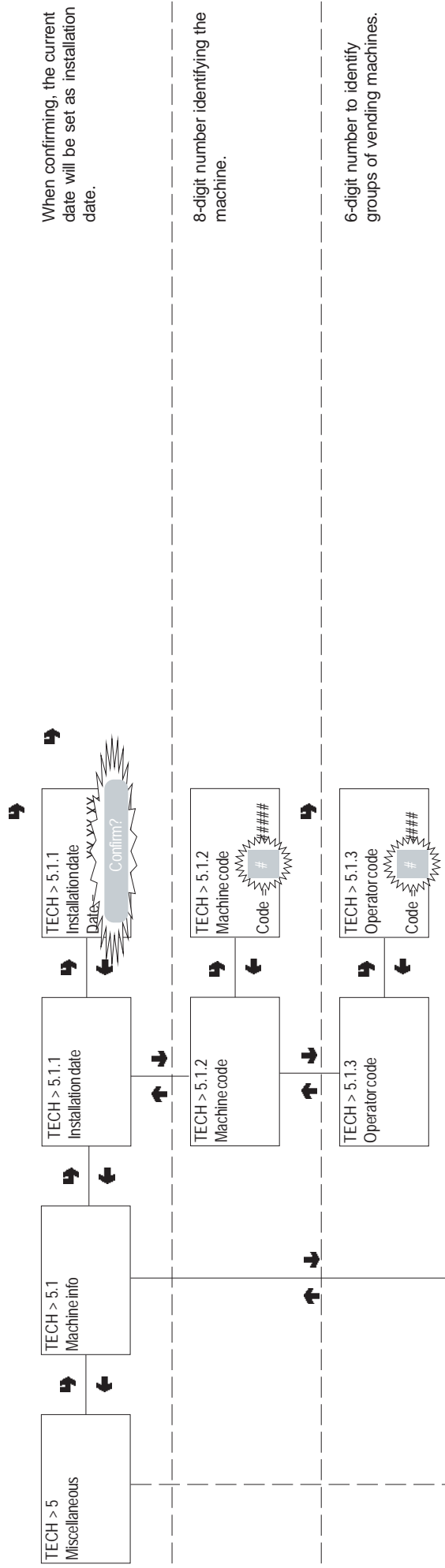

When confirming, the current date will be set as installation date.

8-digit number identifying the machine.

6-digit number to identify groups of vending machines.

INITIALISING DATABASES

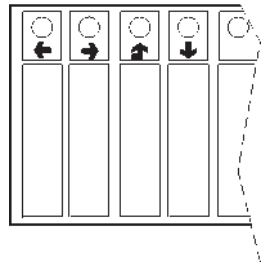
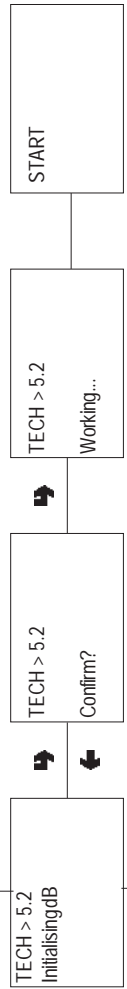

Programming button

Technician menu - Summary

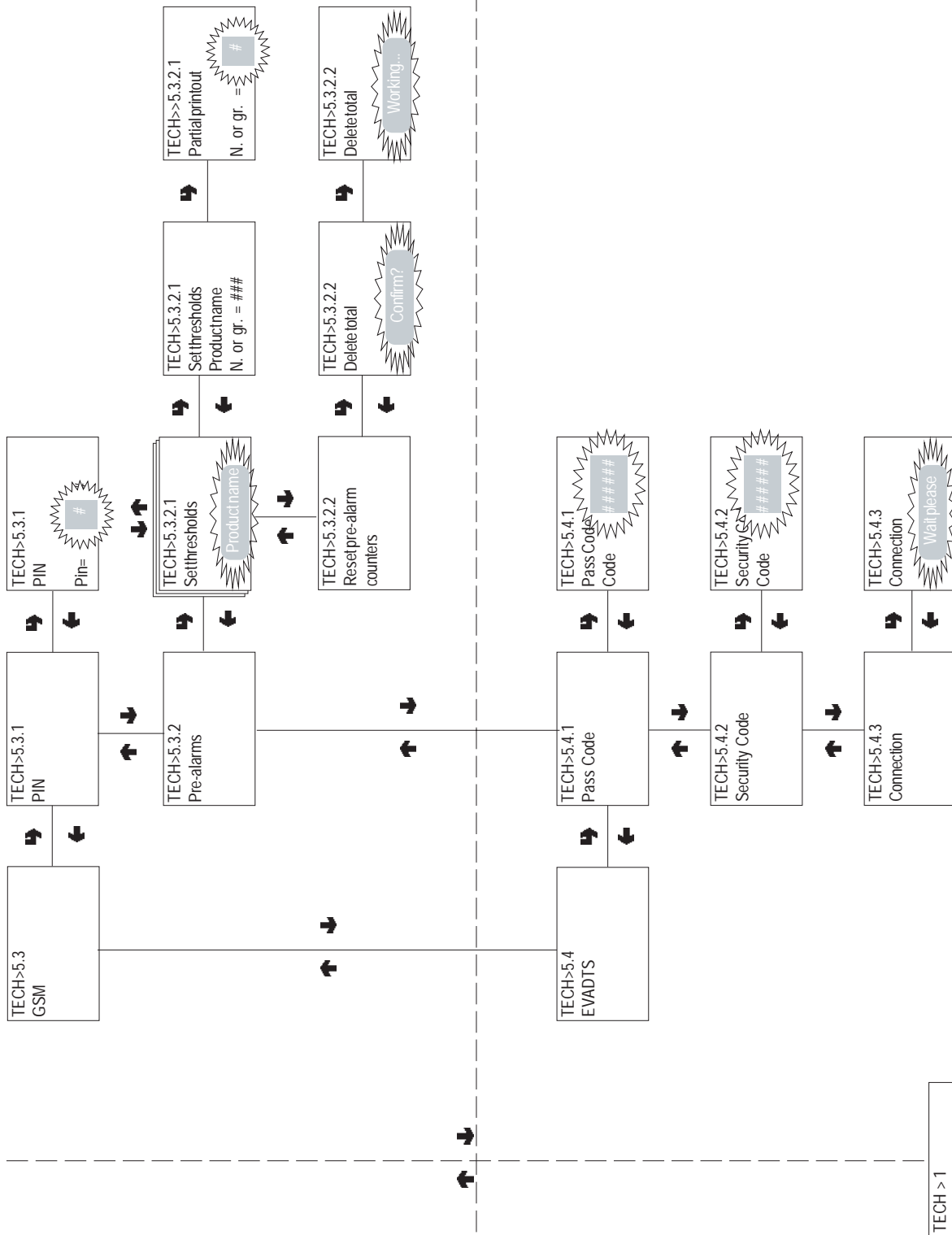

 Programming button

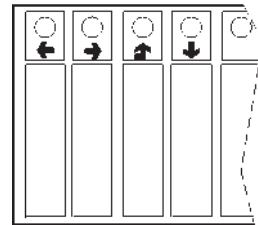

WIRING DIAGRAM LEGEND

INITIALS	DESCRIPTION	INITIALS	DESCRIPTION
ALF	BALLAST	NTC2	EVAPORATOR TEMPERATURE PROB
BDV	BDV COIN MECH CONNECTORS	P1-...	SELECTION BUTTONS
ED1-..	DISK SOLENOIDS	PAG	FAILURE RESET BUTTON
EH	HOT-GAS SOLENOID VALVE	PD	DIODE RECTIFIER
EX	EXECUTIVE COIN MECH CONNECTOR	PIP	PROGRAMMING BUTTON
FA	RADIO INTERFERENCE SUPPRESS	PRD	DISK ROTATION BUTTON
FREE	FREE VENDING SWITCH	R1-...	RELAIS
IG	MAIN SWITCH	RT	BALLAST
LF	LAMP	SAL	VOLTAGE SUPPLY BOARD
MA1-..	SLIDER OPENING MOTOR	SLCD	LIQUID CRYSTAL DISPLAY
MDB	CONNECTOR FOR MDB COIN MECHA	SM	CONTROL BOARD
MIS1-.	SECTOR COUNTER MICROSWITCH	SP	PUSH-BUTTON BOARD
MP1	OPEN DOOR MICROSWITCH	SP1-10	LOADING BUTTONS
MP2	OPEN PAYMENT COMPT. MICROSWIT	ST	STARTER
MRD	DISK MOTOR	SUC	C.P.U. BOARD
MS1-..	SLIDER MICROSWITCH	TEL	REMOTE CONTROL SWITCH
MUR	COMPRESSOR	TR	TRANSFORMER
MVT	FAN	TX....	DELAYED FUSE (X=COURRENT)
NTC1	REFRIG. BOX TEMPERATURE PROBE		

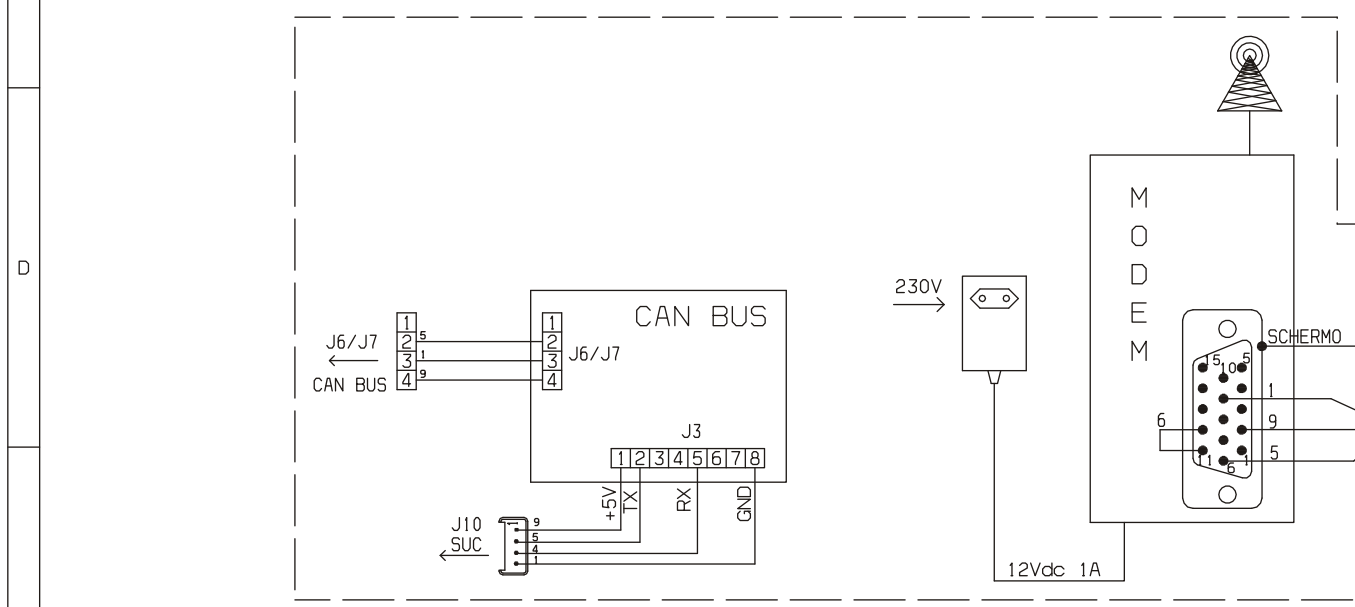
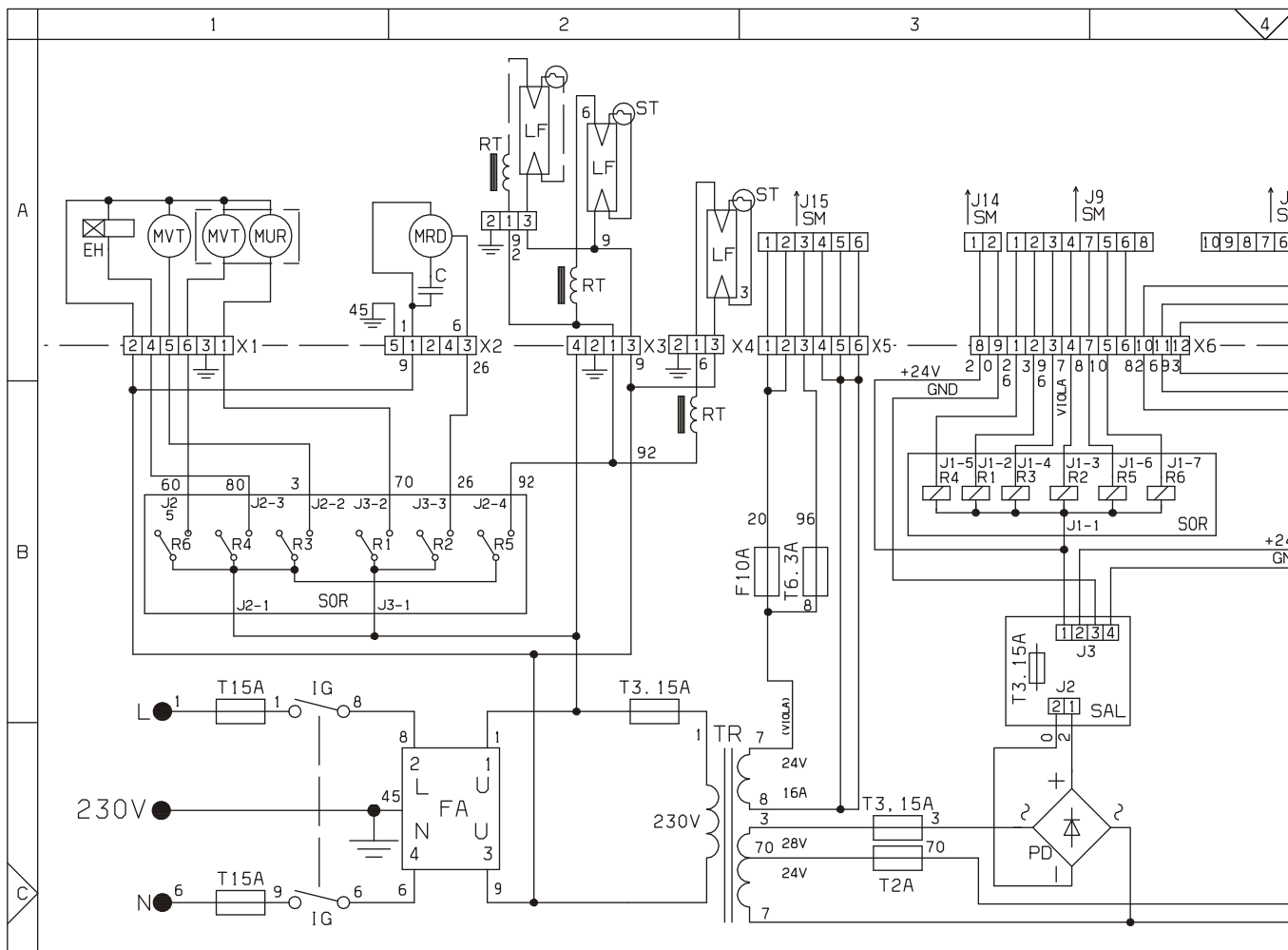

NECTA VENDING SOLUTIONS S.P.A.
 SI RISERVA A TERMINI DI LEGGE
 LA PROPRIETA' DEL PRESENTE
 DISEGNO CON DIVIETO DI
 RIPRODURLO O DIVULGARLO SENZA
 SUA PREVIA AUTORIZZAZIONE

0	NERO	1	MARRONE	2	ROSSO	3	ARANCIO	4	GIALLO	5	VERDE	6	BLU	7	ARZURRO	8	ROSA	9	VIOLEA	0	BRTIGLIO	1	BIANCO	2	BLACK	3	BROWN	4	RED	5	ORANGE	6	YELLOW	7	GREEN	8	BLUE	9	LIGHT BLUE	0	PINK	1	VIOLET	2	GREY	3	WHITE	4	NOIR	5	MARRON	6	ROUGE	7	ORANGE	8	JAUNE	9	VERT	0	BLEU	1	BLEU CIEL	2	ROSE	3	ROSE	4	BLANC	5	GRIS	6	SCHWARZ	7	ROT	8	ORANGE	9	GELB	0	GRUEN	1	BLAU	2	HELLBLAU	3	ROSA	4	LILLA	5	GRAU	6	WEISS	7	NEGRON	8	MARRON	9	ROJO	0	MARANJA	1	AMARILLO	2	VERDE	3	OSCURO	4	AZUL CLARO	5	ROSA	6	ROSA	7	GRIS	8	BLANCO	9	NEVE
---	------	---	---------	---	-------	---	---------	---	--------	---	-------	---	-----	---	---------	---	------	---	--------	---	----------	---	--------	---	-------	---	-------	---	-----	---	--------	---	--------	---	-------	---	------	---	------------	---	------	---	--------	---	------	---	-------	---	------	---	--------	---	-------	---	--------	---	-------	---	------	---	------	---	-----------	---	------	---	------	---	-------	---	------	---	---------	---	-----	---	--------	---	------	---	-------	---	------	---	----------	---	------	---	-------	---	------	---	-------	---	--------	---	--------	---	------	---	---------	---	----------	---	-------	---	--------	---	------------	---	------	---	------	---	------	---	--------	---	------

Sx35703



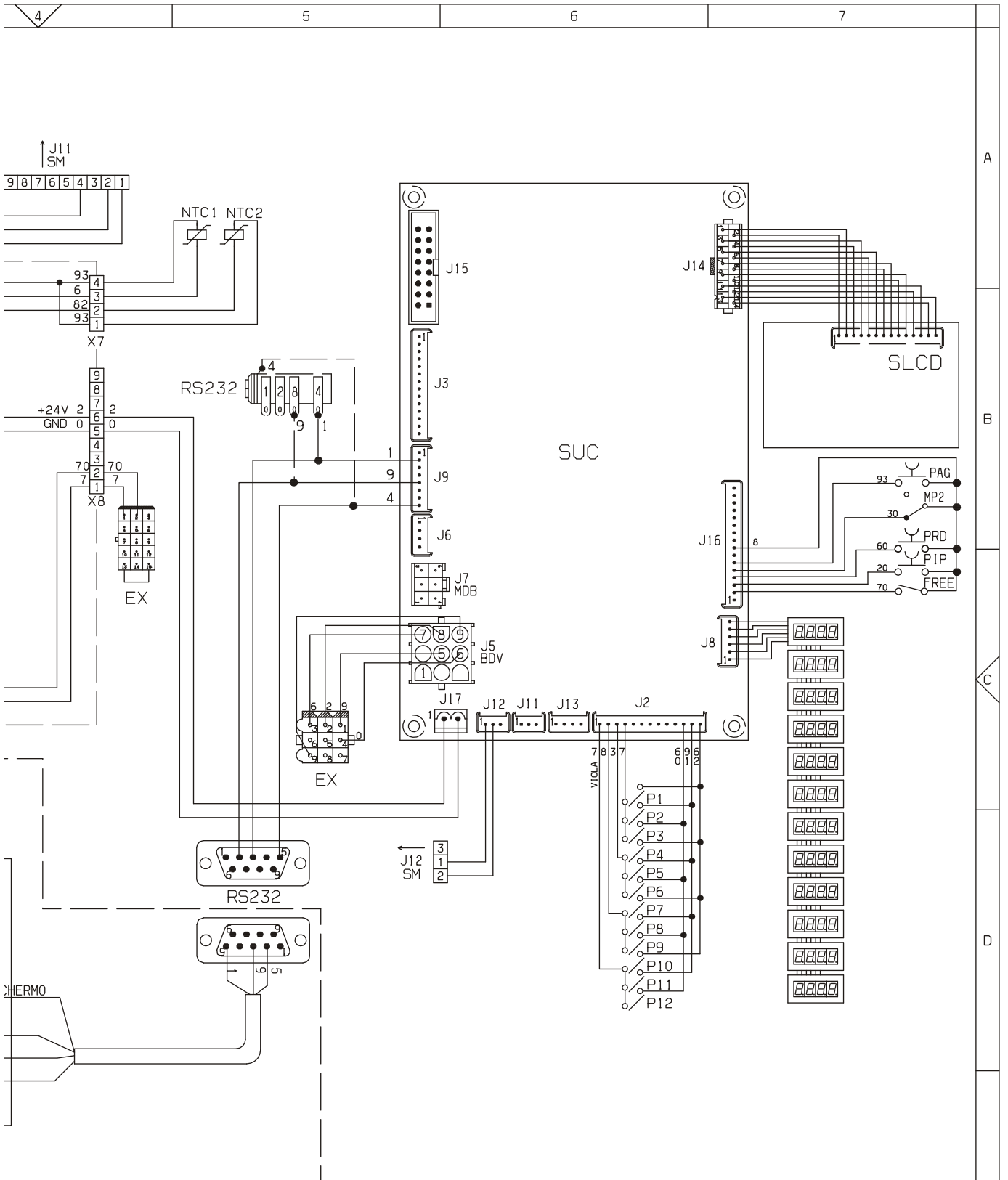

ROSA GRIGIO BIANCO	NECTA VENDING SOLUTIONS SpA A company of N&W GLOBAL VENDING GROUP	MODELLO StarFood	GRUPPO SCHEMA ELETTRICO FUNZIONALE ALIMENTAZIONE-PORTA	DATA 27-10-00	FOGLIO 1/1	DISEGNATO BONACINA	CONTROLLATO MONGUZZI
	LEGENDA						
	CODICE 608535703						



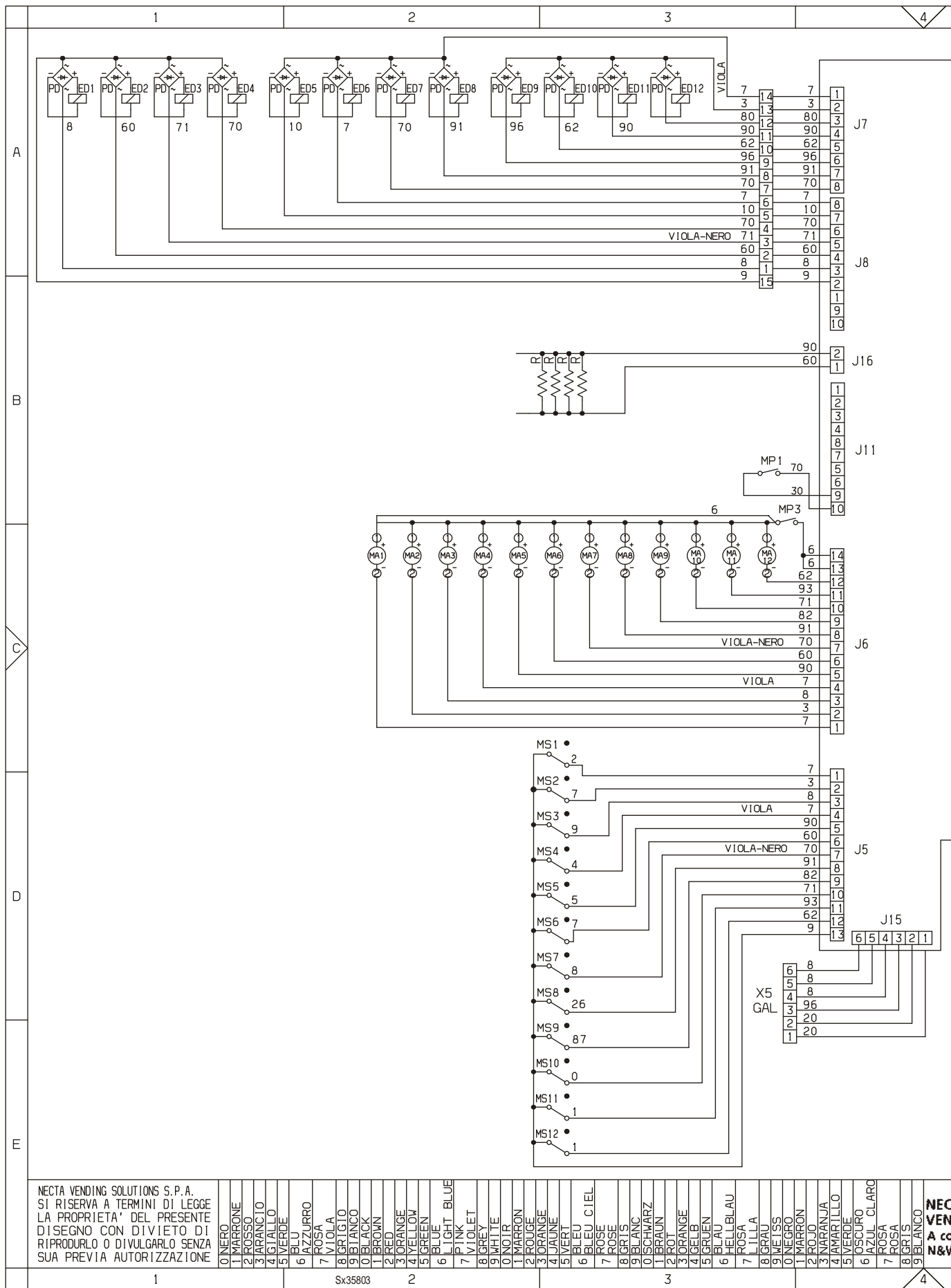

NECTA VENDING SOLUTIONS S.P.A.
 SI RISERVA A TERMINI DI LEGGE
 LA PROPRIETA' DEL PRESENTE
 DISEGNO CON DIVIETO DI
 RIPRODURLO O DIVULGARLO SENZA
 SUA PREVIA AUTORIZZAZIONE

1	0 NERO	1 MARRONE	2 ROSSO	3 ARANCIO	4 GIALLO	5 VERDE	6 AZZURRO	7 ROSA	8 GRIGIO	9 BIANCO	0 BLACK	1 BROWN	2 RED	3 ORANGE	4 YELLOW	5 GREEN	6 BLUE	7 LIGHT BLUE	8 VIOLET	9 GREY	0 NOIR	1 MARRON	2 ROUGE	3 ORANGE	4 JAUNE	5 VERT	6 BLEU CIEL	7 ROSE	8 GRIS	9 BLANC	0 SCHWARZ	1 BRAUN	2 ROT	3 ORANGE	4 GELB	5 GRUEN	6 HELLBLAU	7 ROSA	8 LILA	9 GRAU	0 WEISS	1 MARRON	2 FOJO	3 NARANJA	4 AMARILLO	5 VERDE	6 OSCURO	7 AZUL CLARO	8 ROSA	9 BLANCO	0 NECTA VENI A cor N&W																																																
1	Sx35803																								2																									3																									4																								



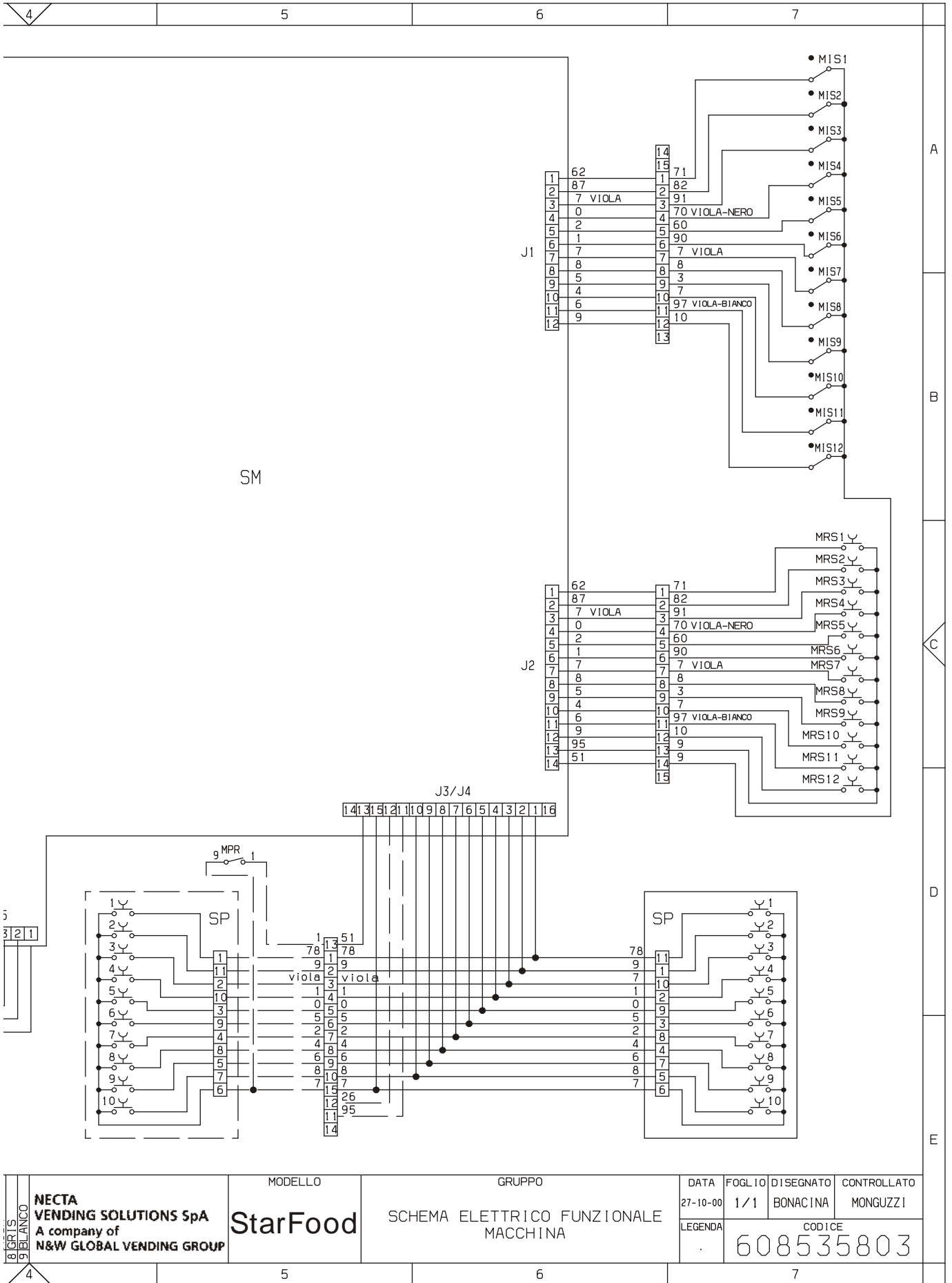

BICRIS SIBLANCO	NECTA VENDING SOLUTIONS SpA A company of N&W GLOBAL VENDING GROUP	MODELLO StarFood	GRUPPO SCHEMA ELETTRICO FUNZIONALE MACCHINA	DATA 27-10-00	FOGLIO 1/1	DISEGNATO BONACINA	CONTROLLATO MONGUZZI
					LEGENDA	CODICE 608535803	
	4	5	6	7			



The Manufacturer reserves the right to modify, without prior notice, the characteristics of the equipment described in this publication; and further declines to accept any responsibility for any inaccuracies contained in this publication which can be ascribed to printing and/or transcription errors.

All instructions, drawings, tables and information contained in this publication are confidential and can neither be reproduced completely or in part, nor be transmitted to third parties without the written permit of the Manufacturer, who has the sole ownership.

EDITION 04 01 CODE: H 171U 02

